



Colegio Santa María de Maipú  
Departamento de Inglés  
Miss Constanza Urrutia

*English is fun !!*



Name:

Kinder:



**English commands:**

Listen, repeat and color the commands.

1.- Listen



2.- Raise your hand



3.- Sit down



**Unit 1: Numbers and colors (1 - 3):**

Trace number ONE and paint the pencil with color RED.

one

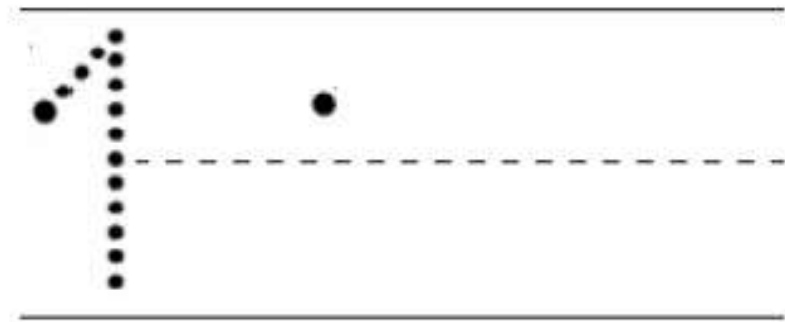
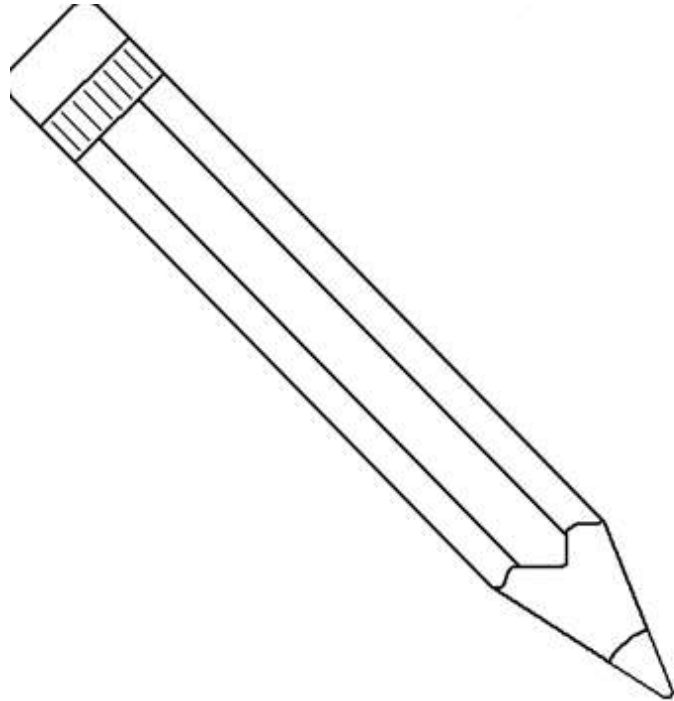

Trace number TWO and paint the balls with color BLUE.

TWO

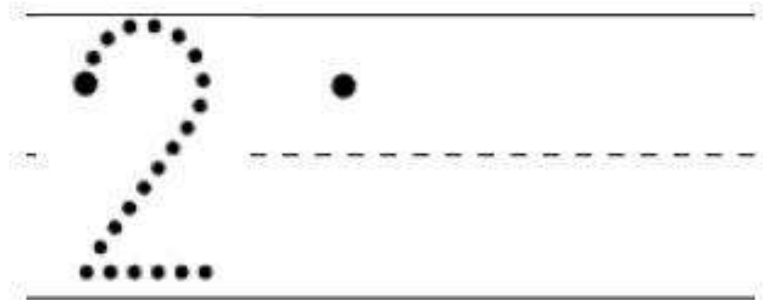
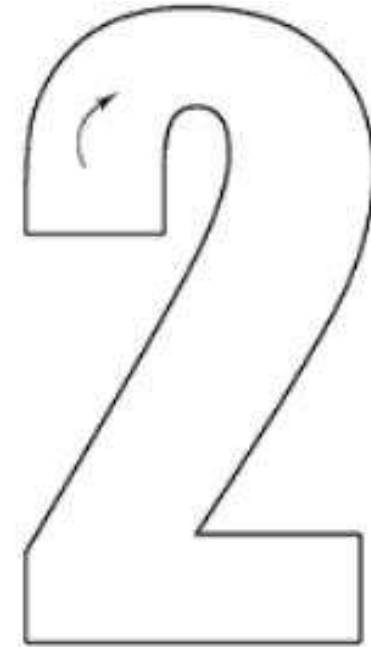
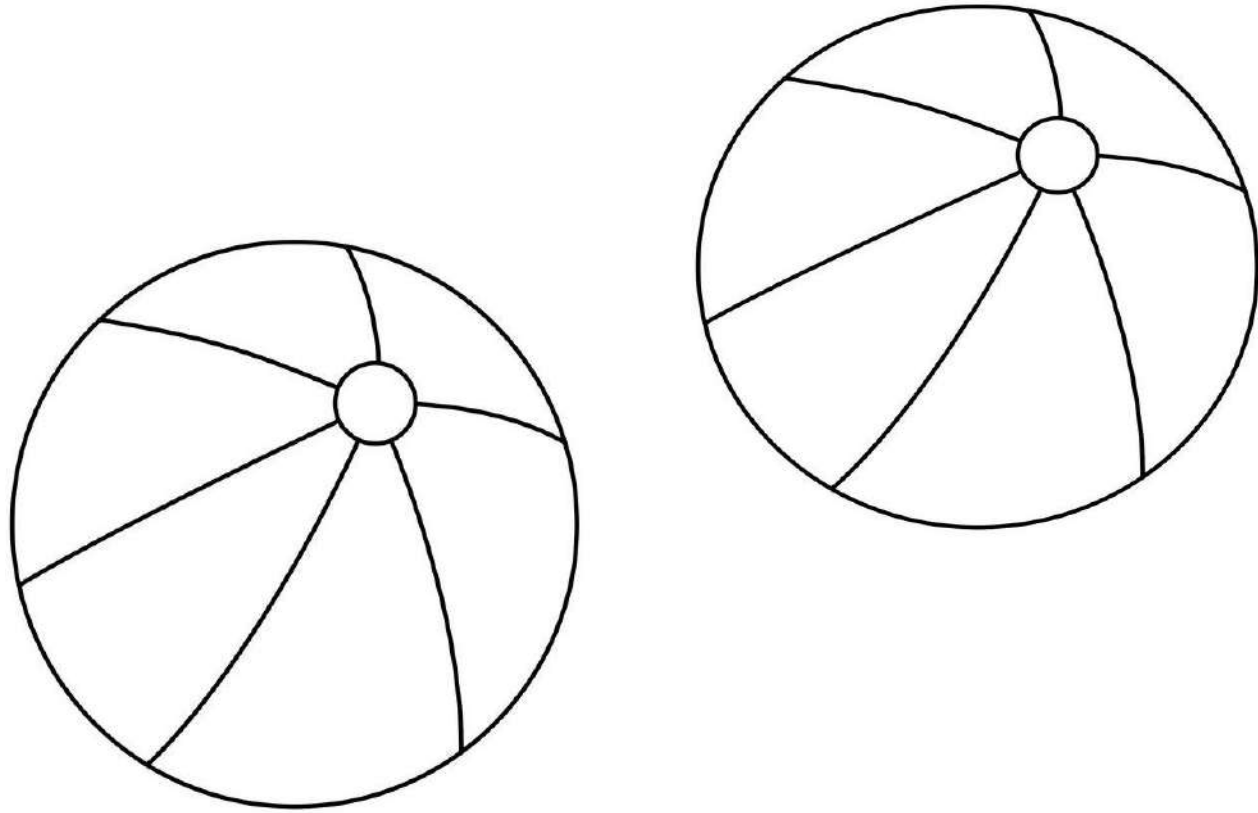

Trace number THREE and paint the flowers with color YELLOW.

# Three

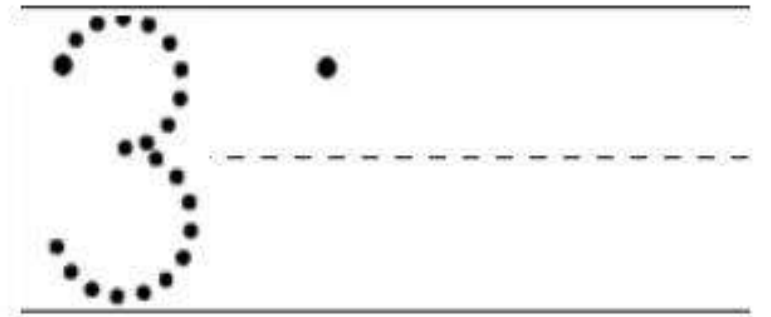
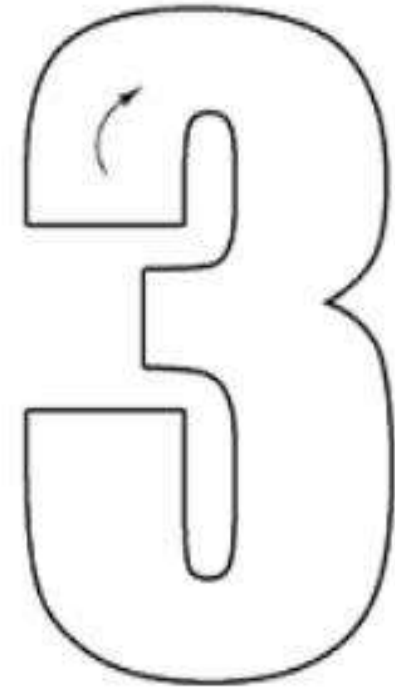

Look and trace the number with the correct images.

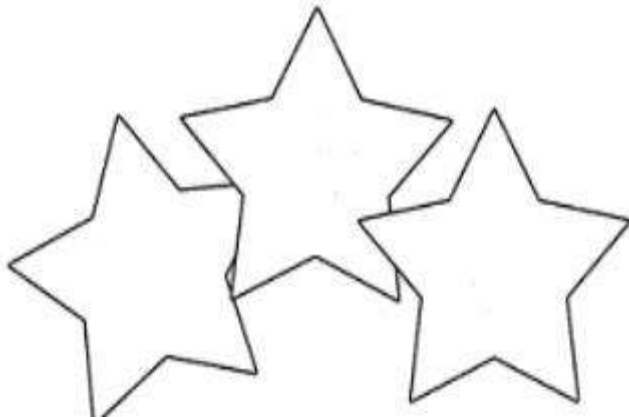
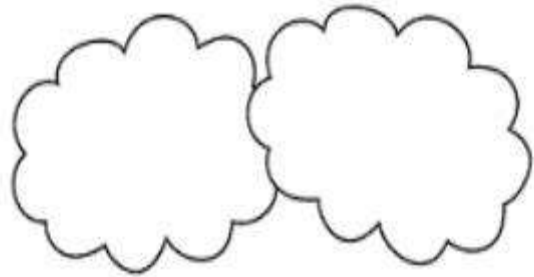

Repeat the numbers and paint it.

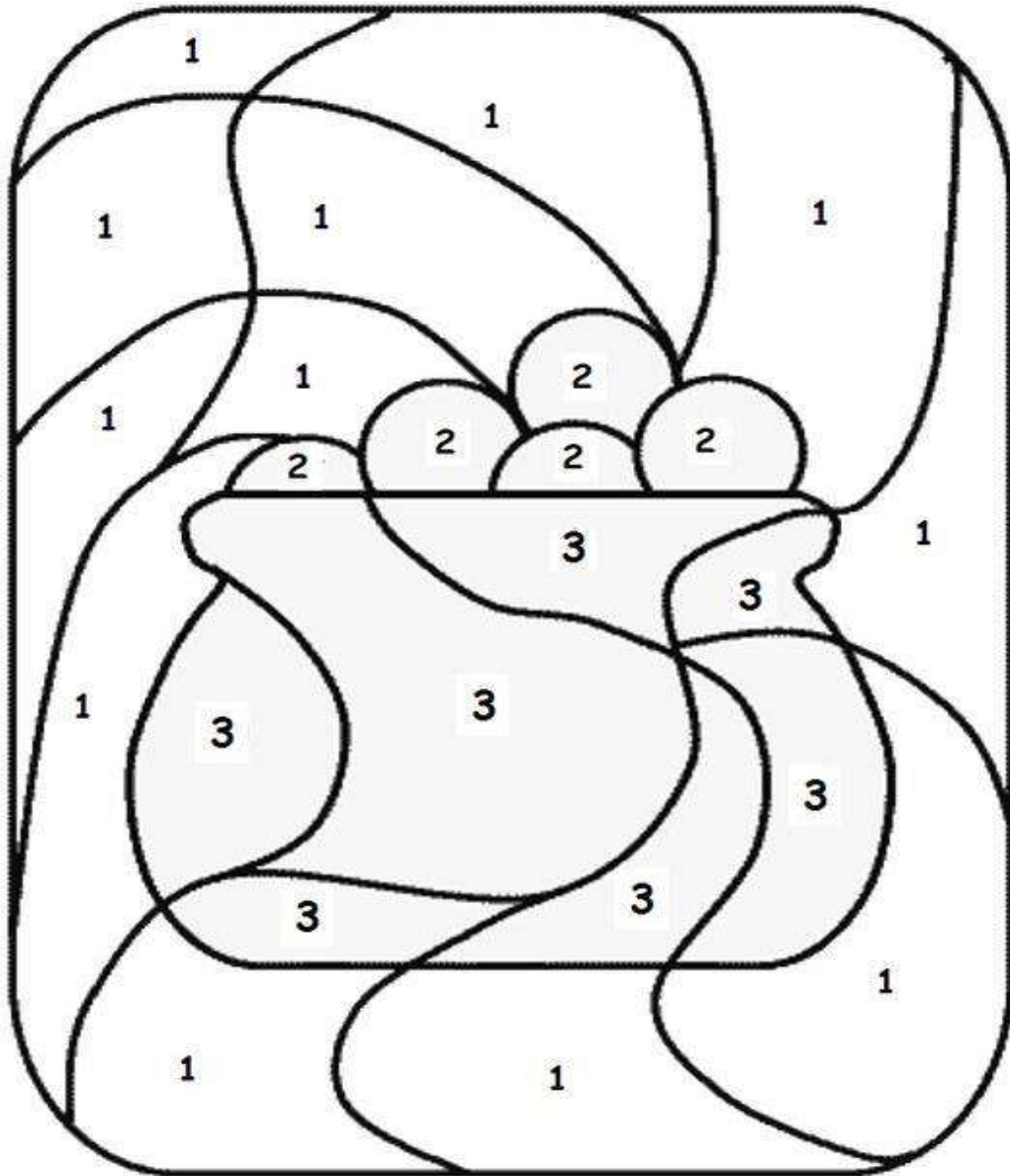

**1. Blue**

**2. Yellow**

**3. Red**

## ***UNIT 2: School supplies***

1. Pencil case

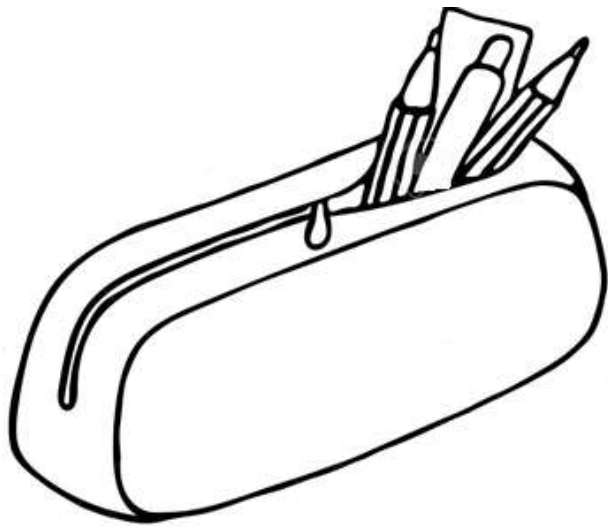

2. Pencil

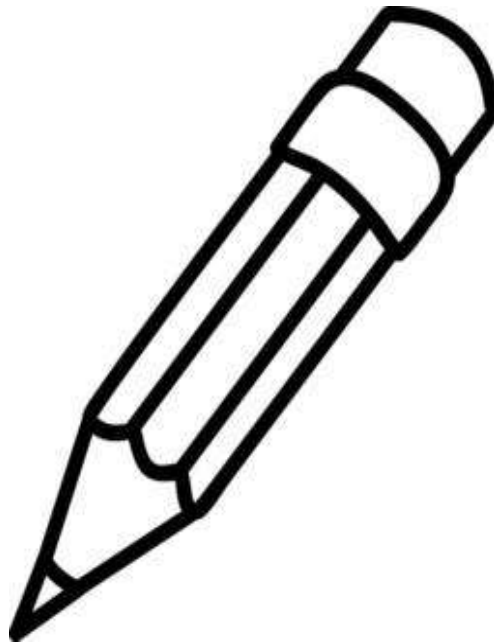

3. Book





Trace and fill the pencil case with ripped papers.

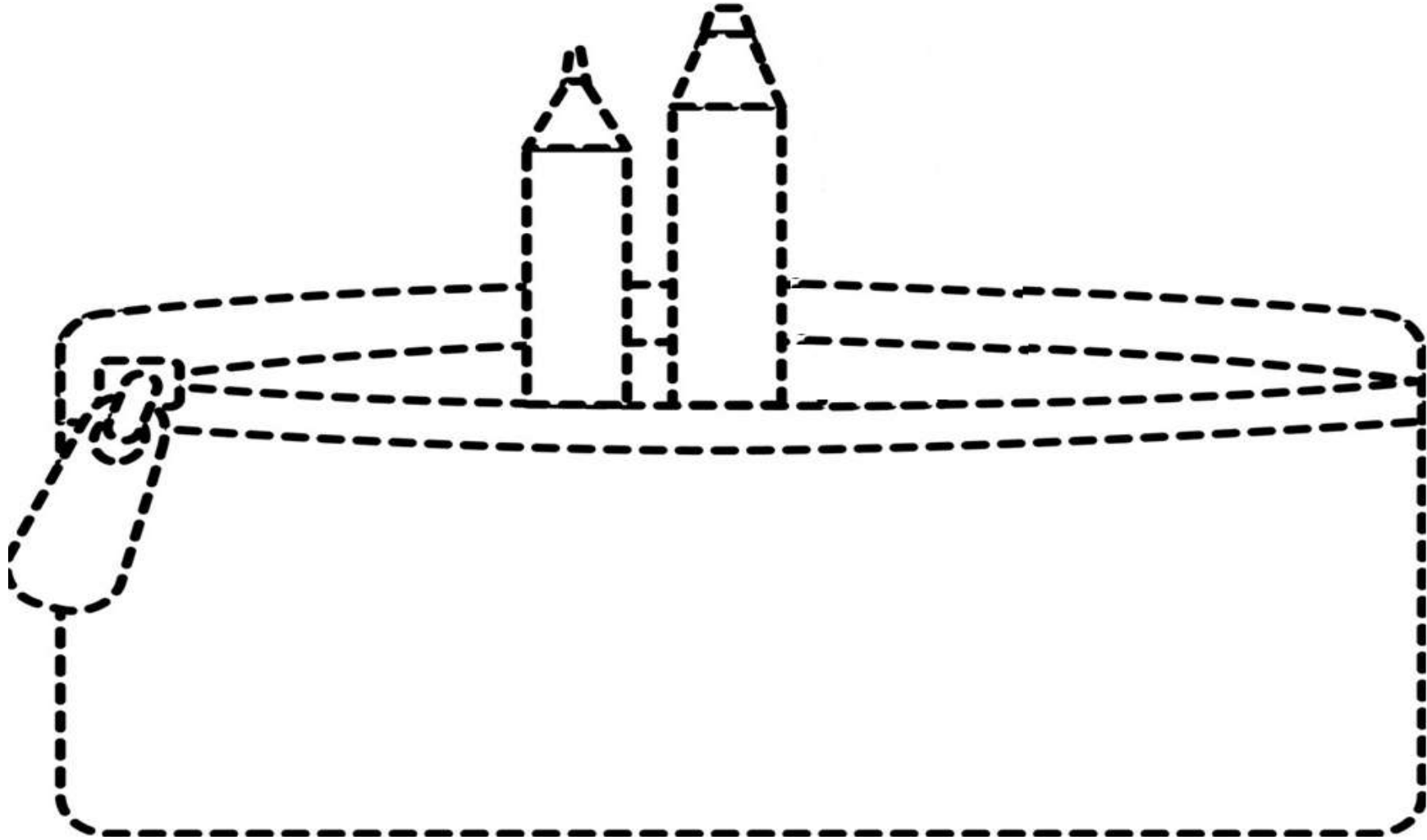

Trace the lines with the correct colors.

Red

Blue

Yellow

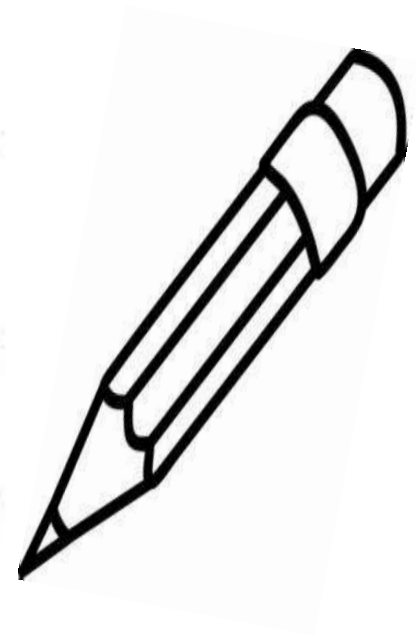
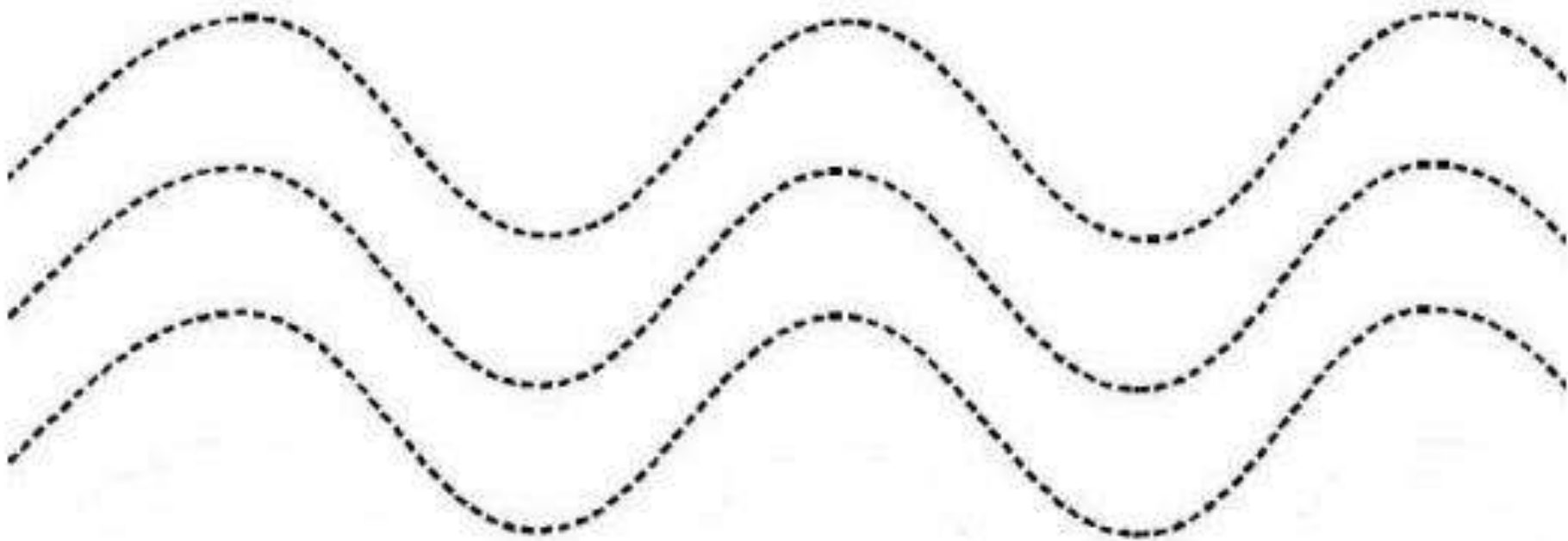

Fill in the book with blue dots.

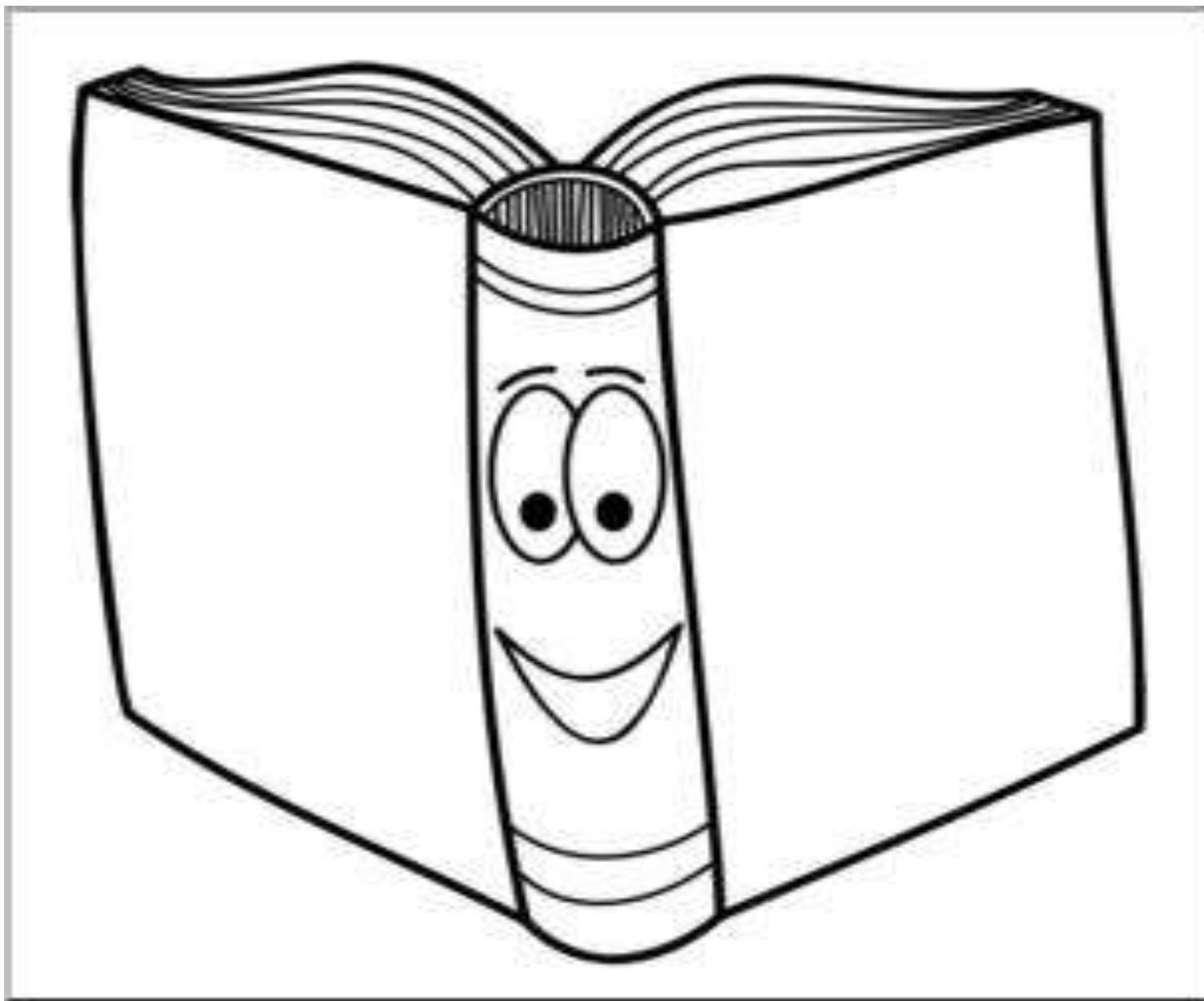

***UNIT 3: Shapes***

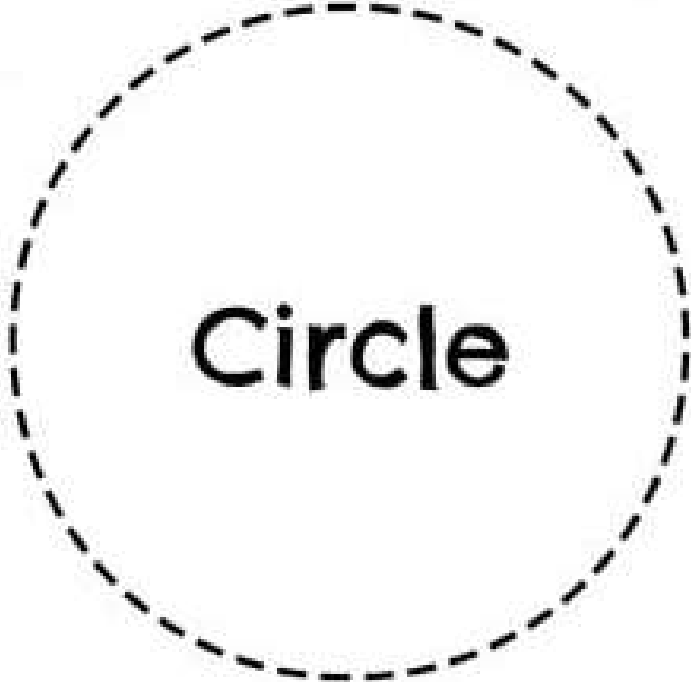
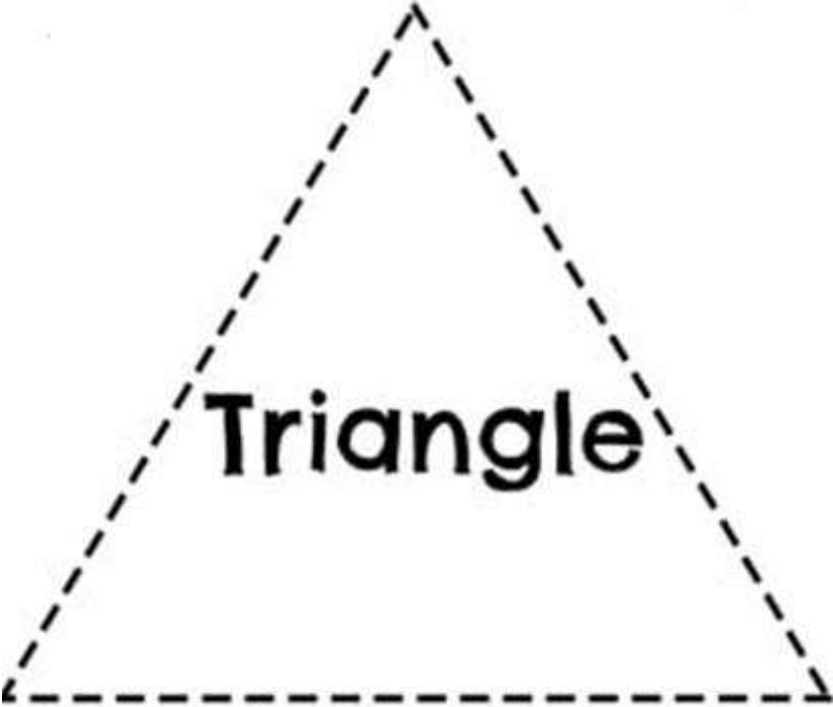

Repeat the name of the shape (TRIANGLE) and follow the instructions

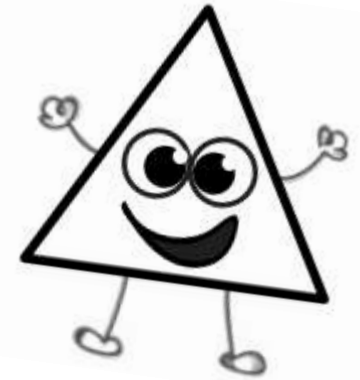

**1** Trace the shape.

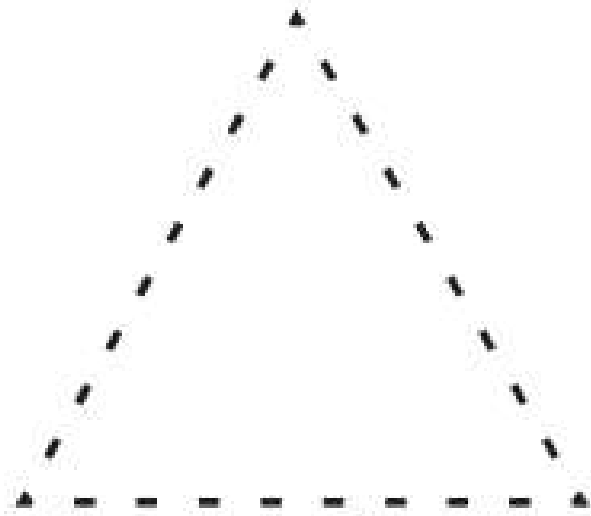

**2** Connect the dots.

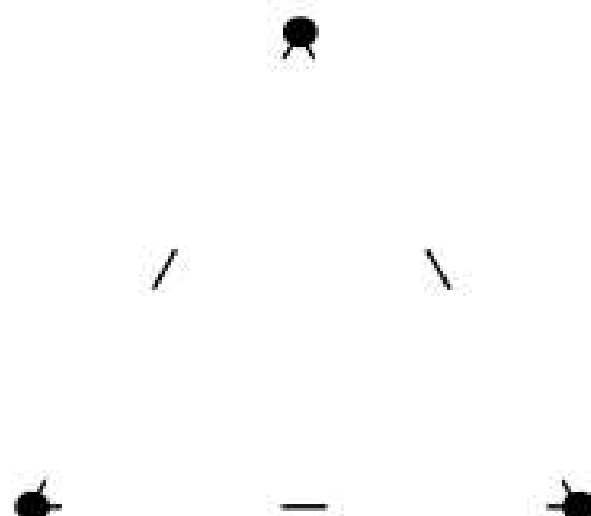

**3** Draw the shape.

Repeat the name of the shape (CIRCLE) and follow the instructions



**1** Trace the shape.

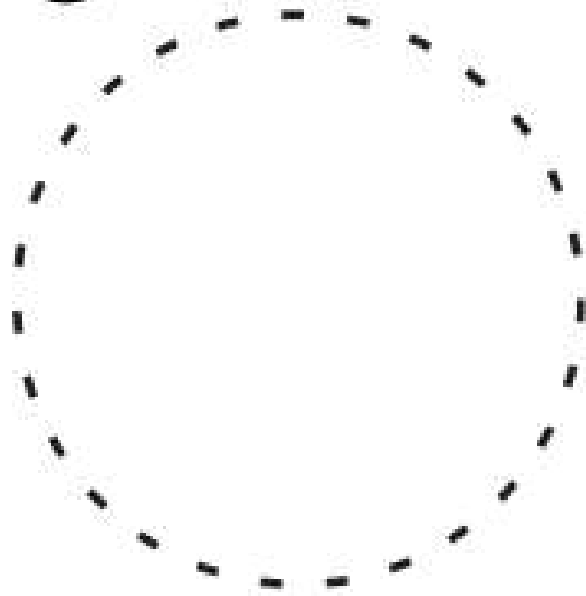

**2** Connect the dots.

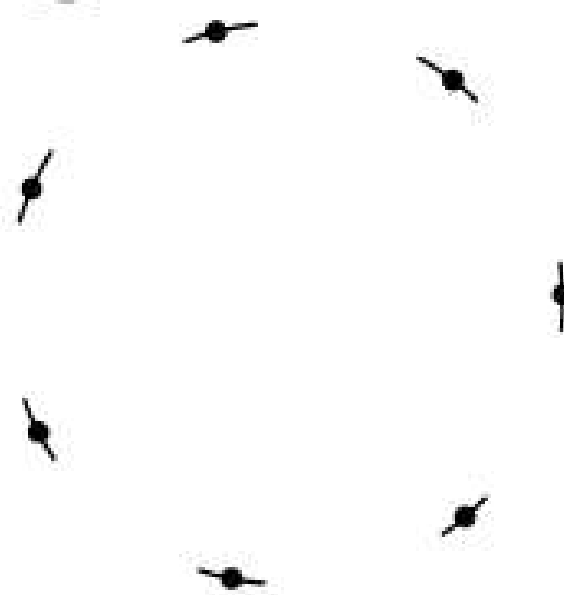

**3** Draw the shape.

-Identify the triangles and paint it color yellow.

-Identify the circles and paint it color orange.

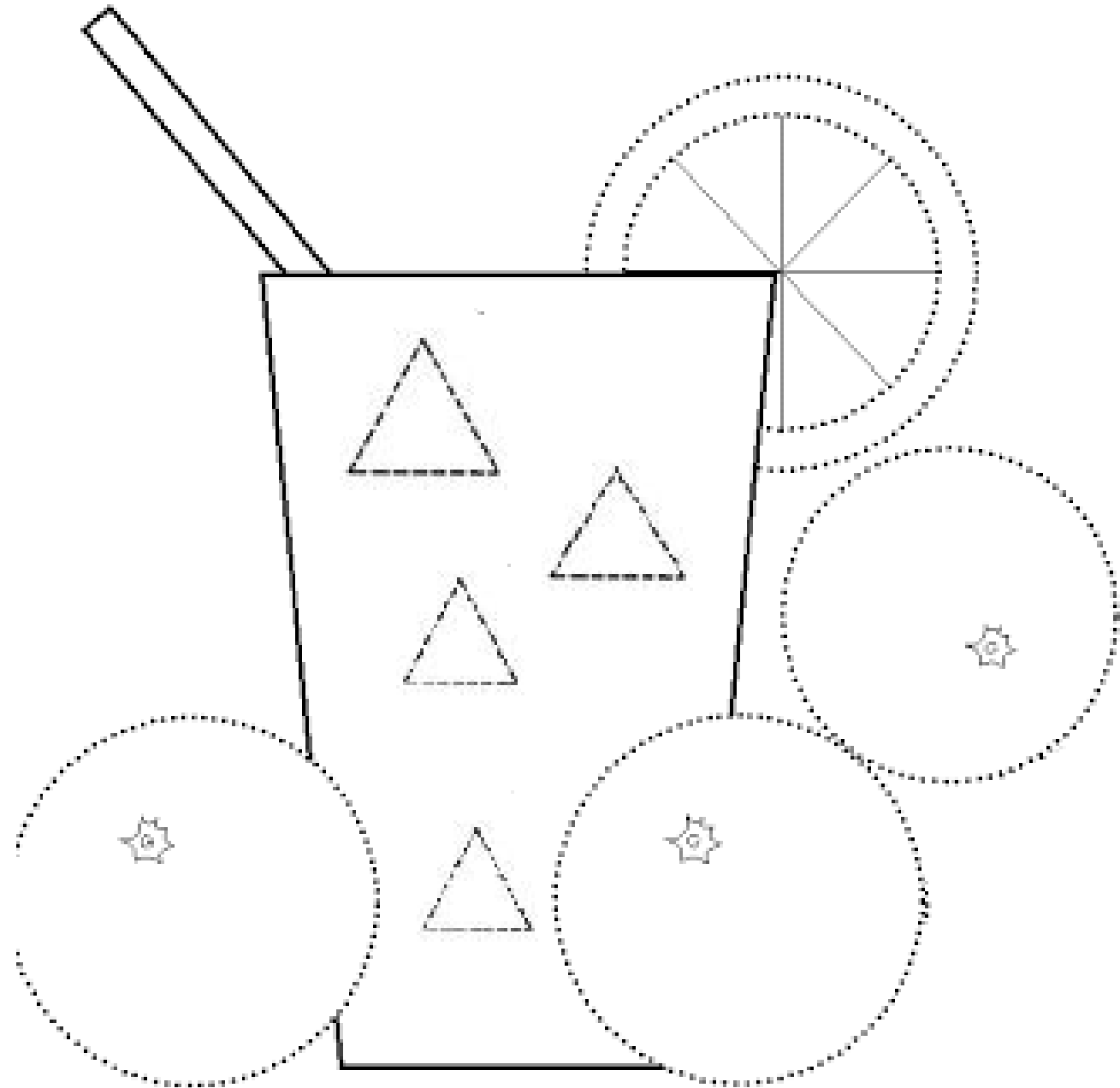

Trace number FOUR and paint the apples with color green.

four

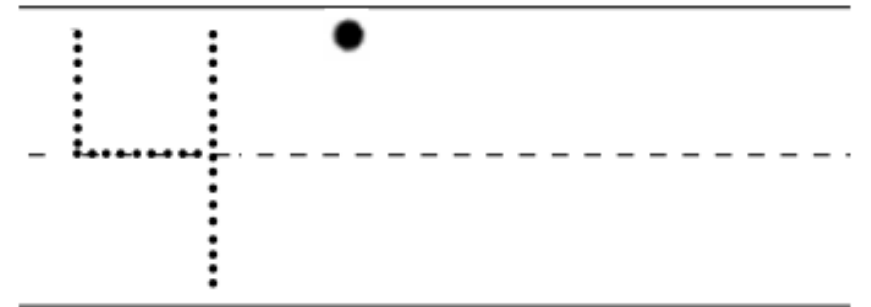
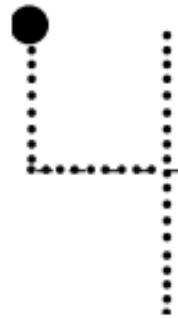
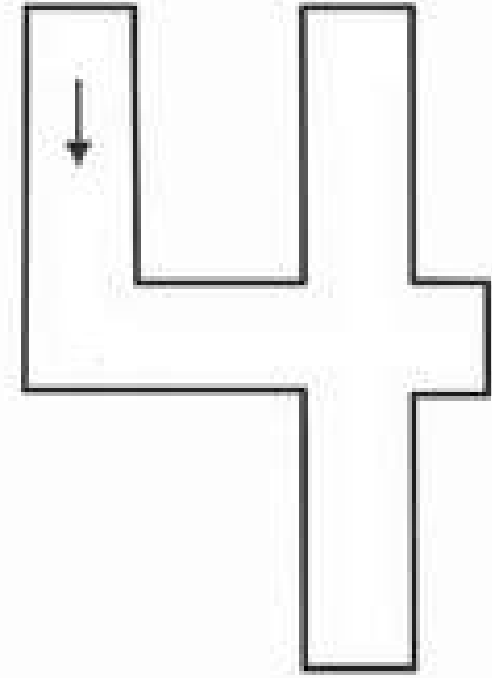
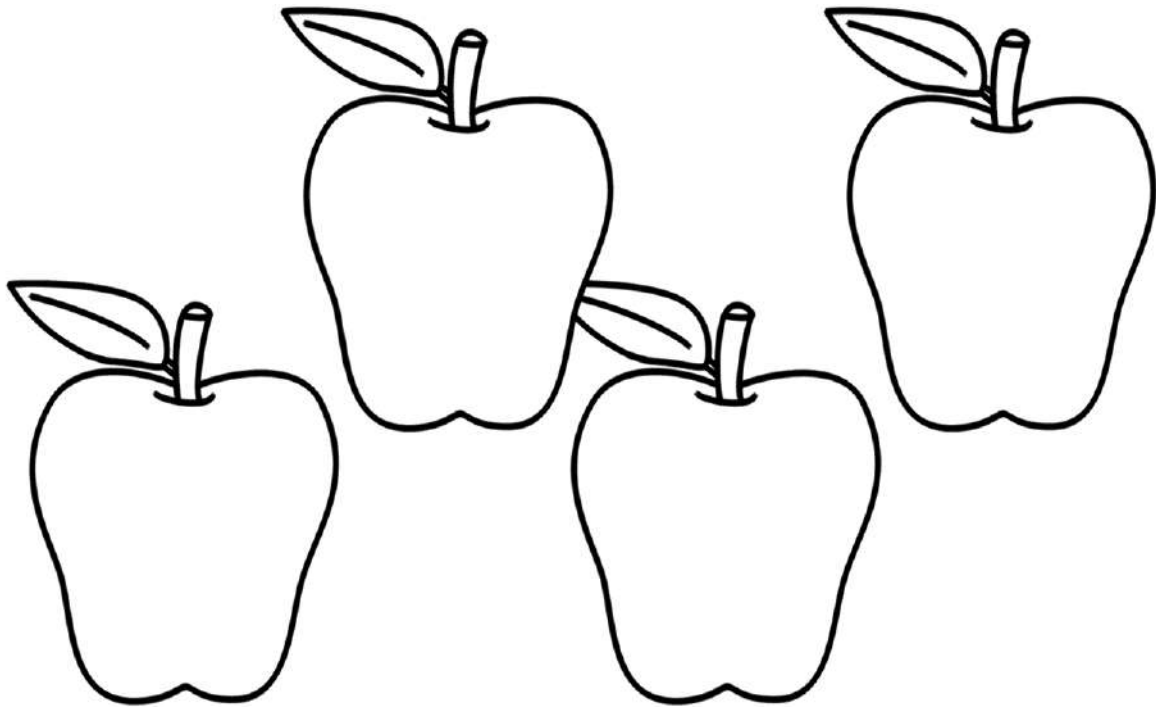



Trace number FIVE and paint the cupcakes with color pink.

five

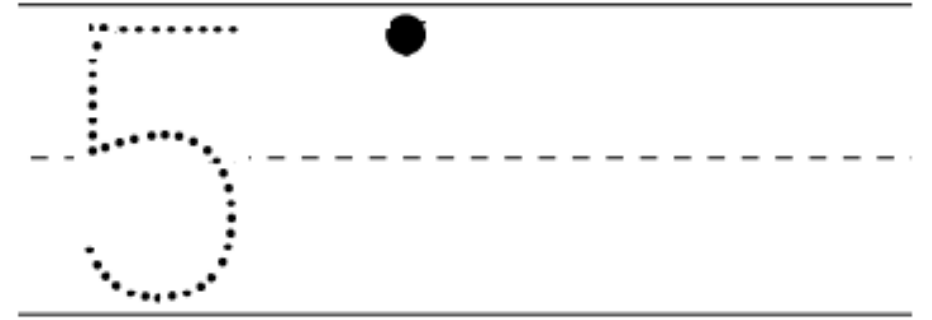

## UNIT 4: Food

Orange



Apple

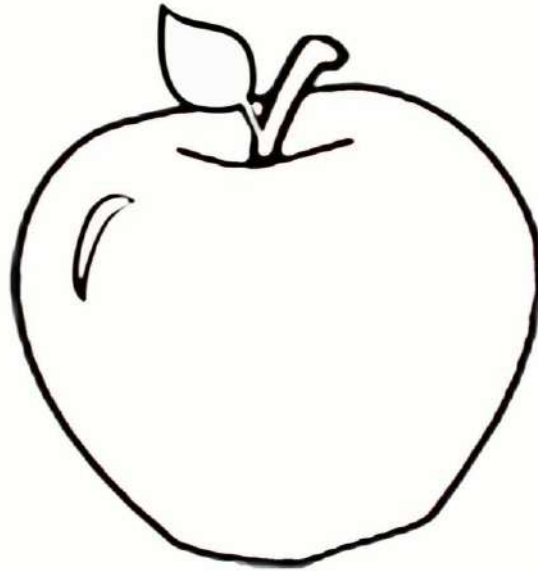

Banana

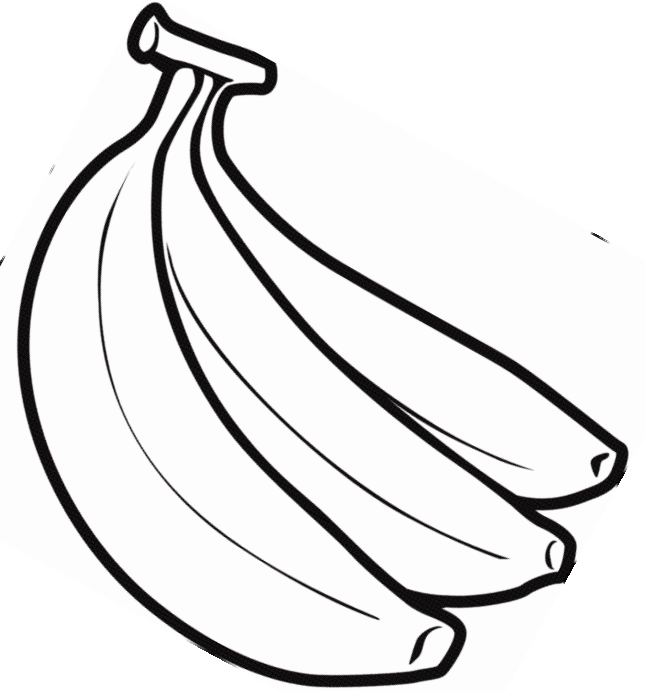

## *Lunch box activity*

Listen and draw:

- Two apples
- Four bananas
- Five oranges

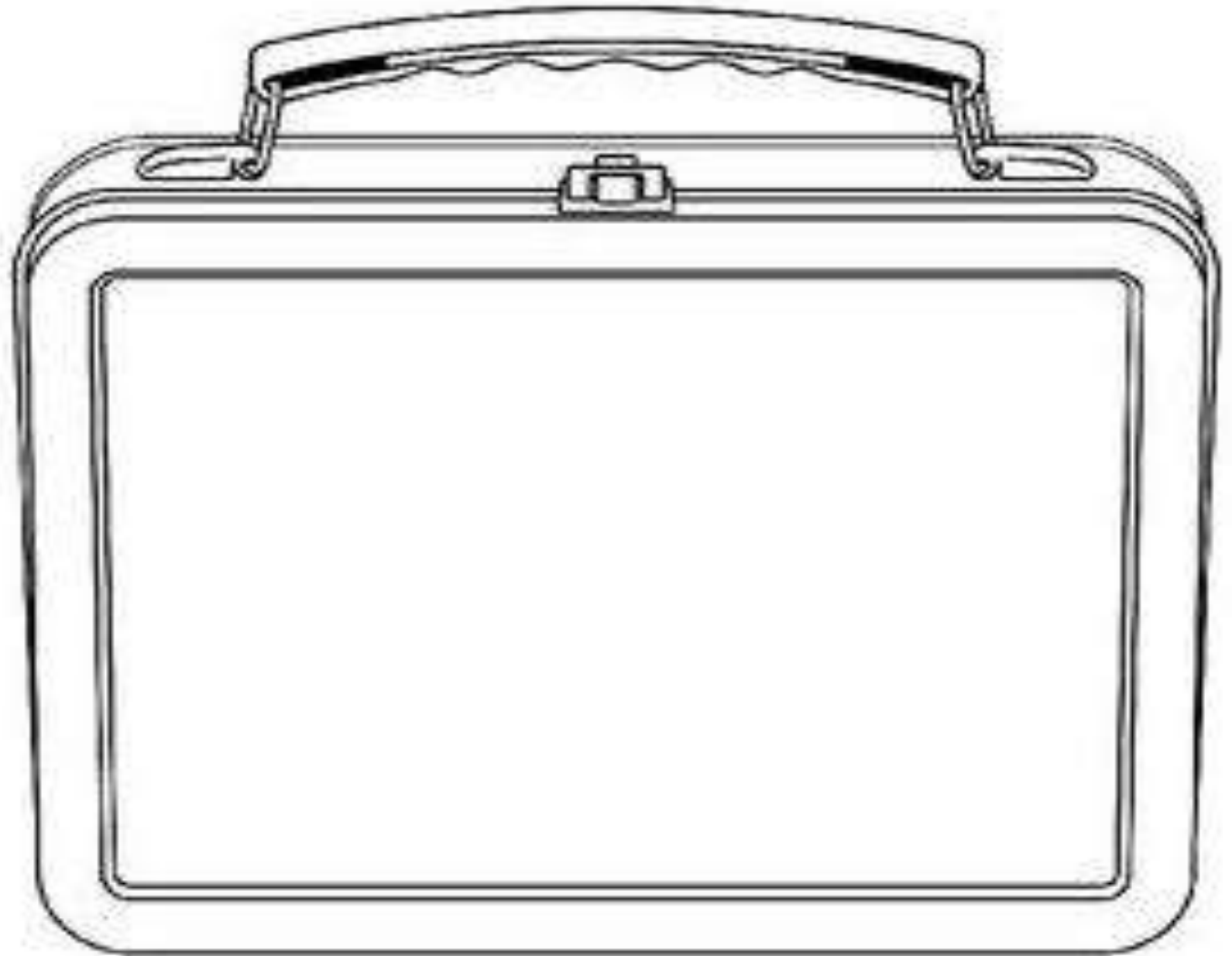

Complete and color the fruits.

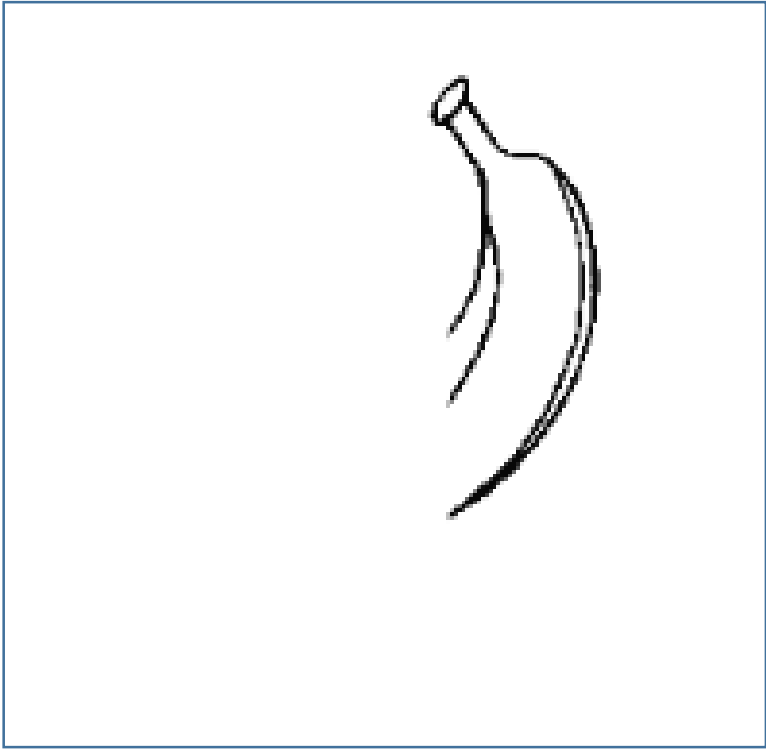
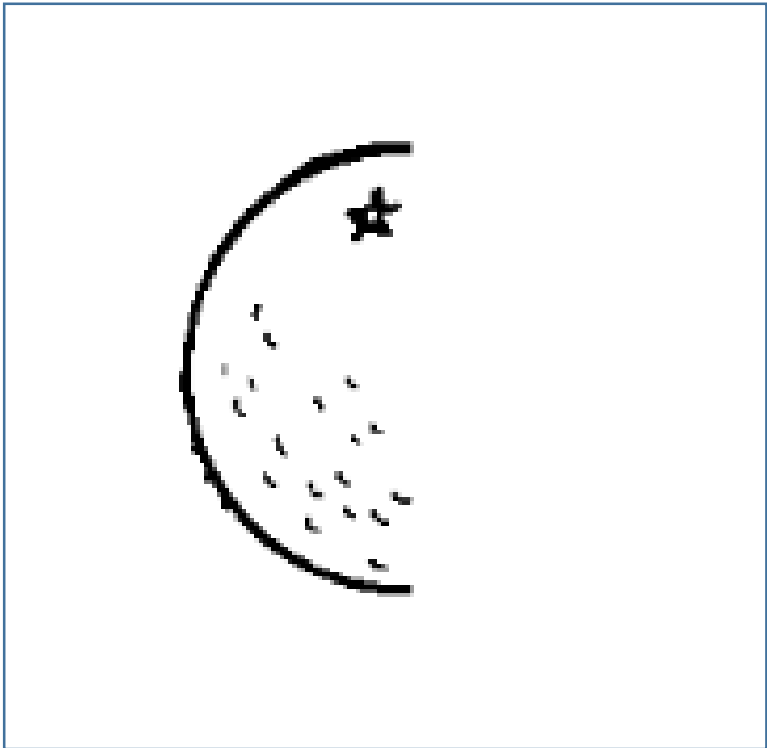
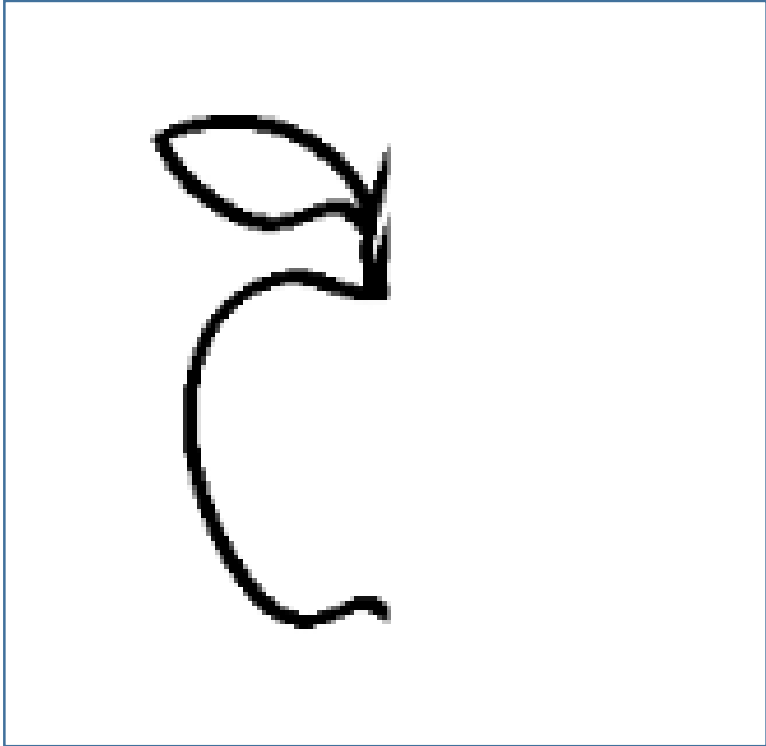

## ***Activity:***

- One plate (un plato)
- *Traerlo cortado de la casa, observar primer imagen.*
- Red paper (papel lustre rojo)
- Green paper (papel lustre verde)
- Glue (pegamento)



## Colors:

- Listen the song about colors and paint the plane according to the image.

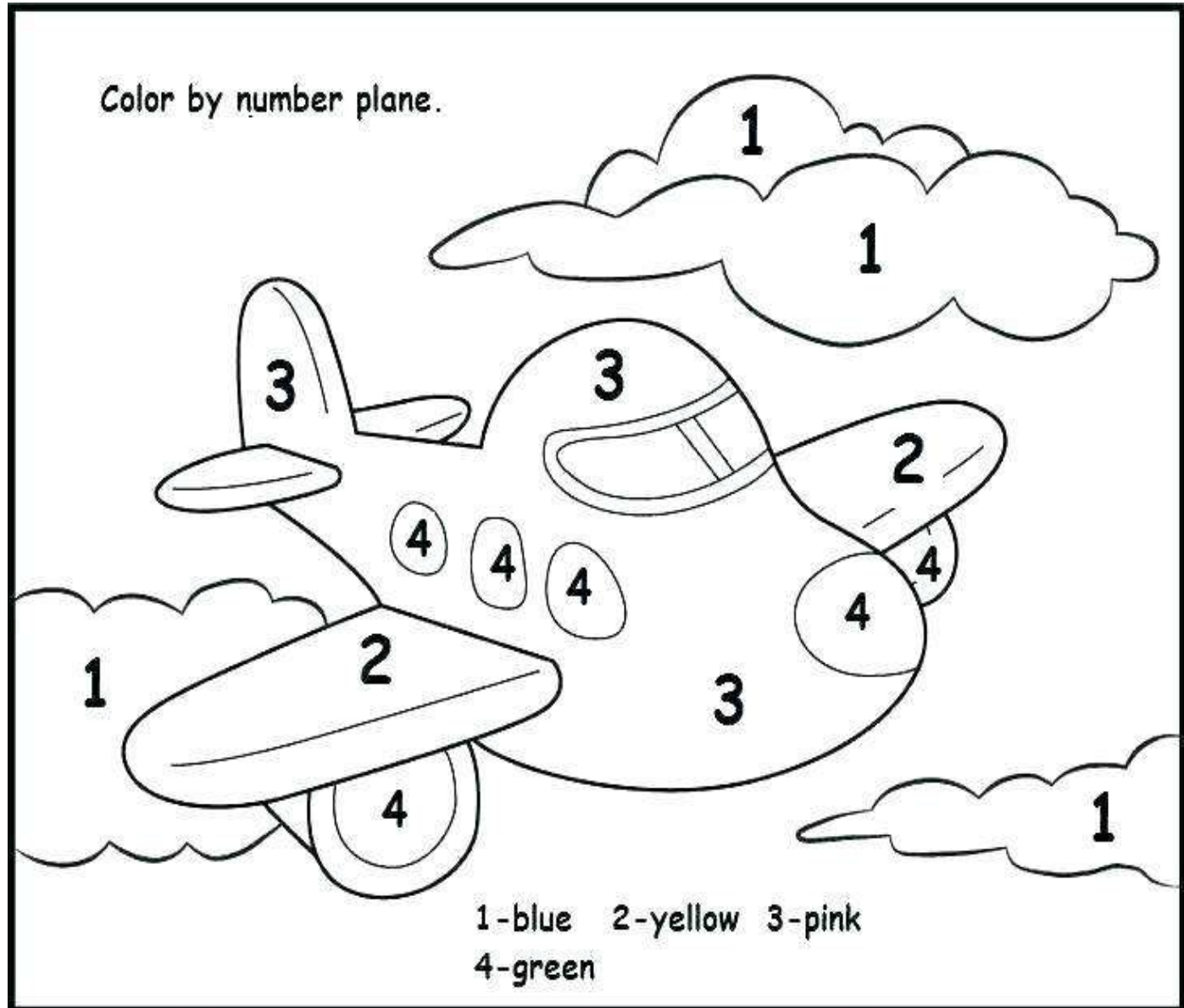

## Color mixing

-Paint: blue, red and yellow (pintura color azul, roja y amarilla).

-Wet towels (toallitas húmedas)

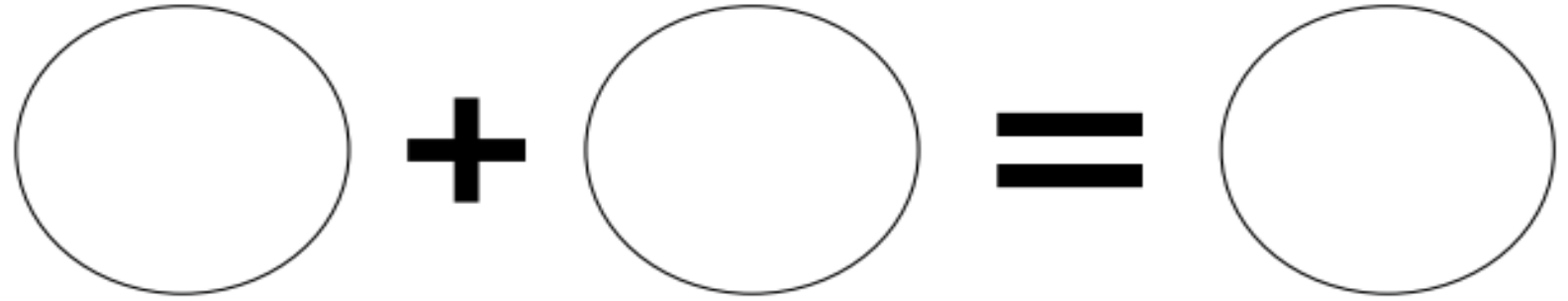

blue + red = purple

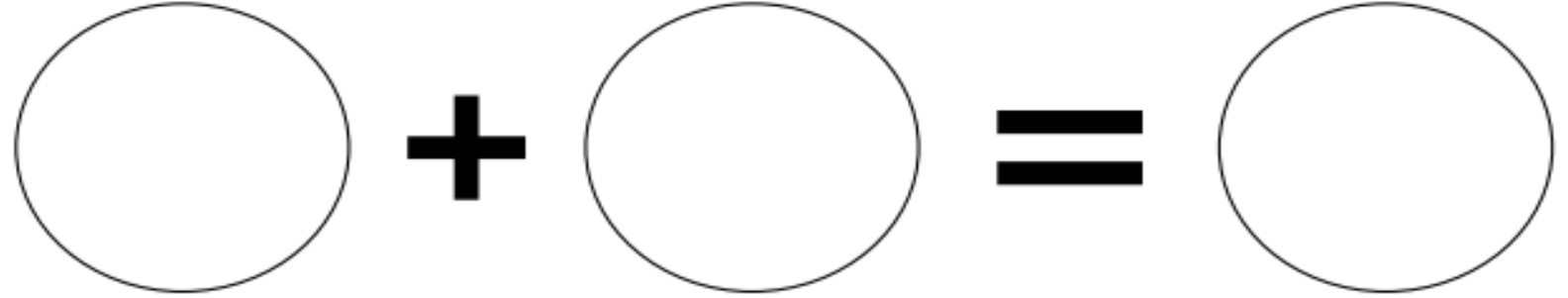

blue + yellow = green

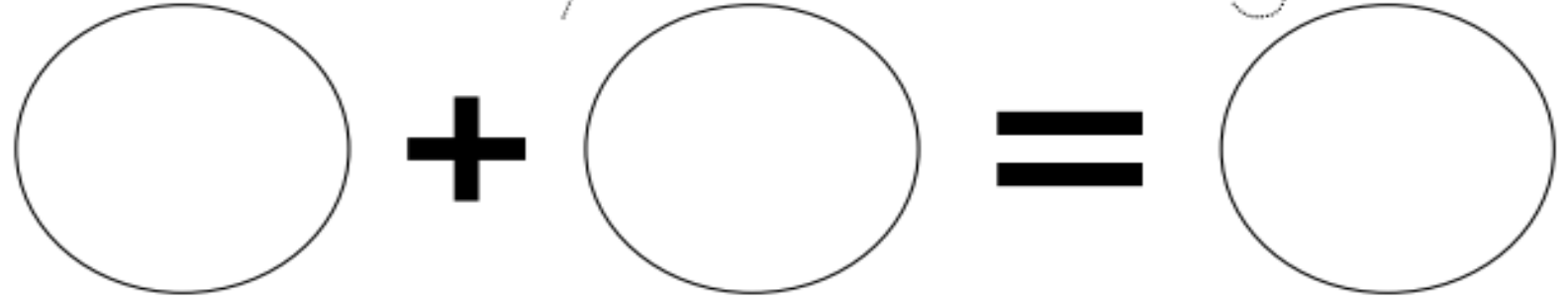

red + yellow = orange

Trace number SIX and paint the leaves with color orange.

SIX

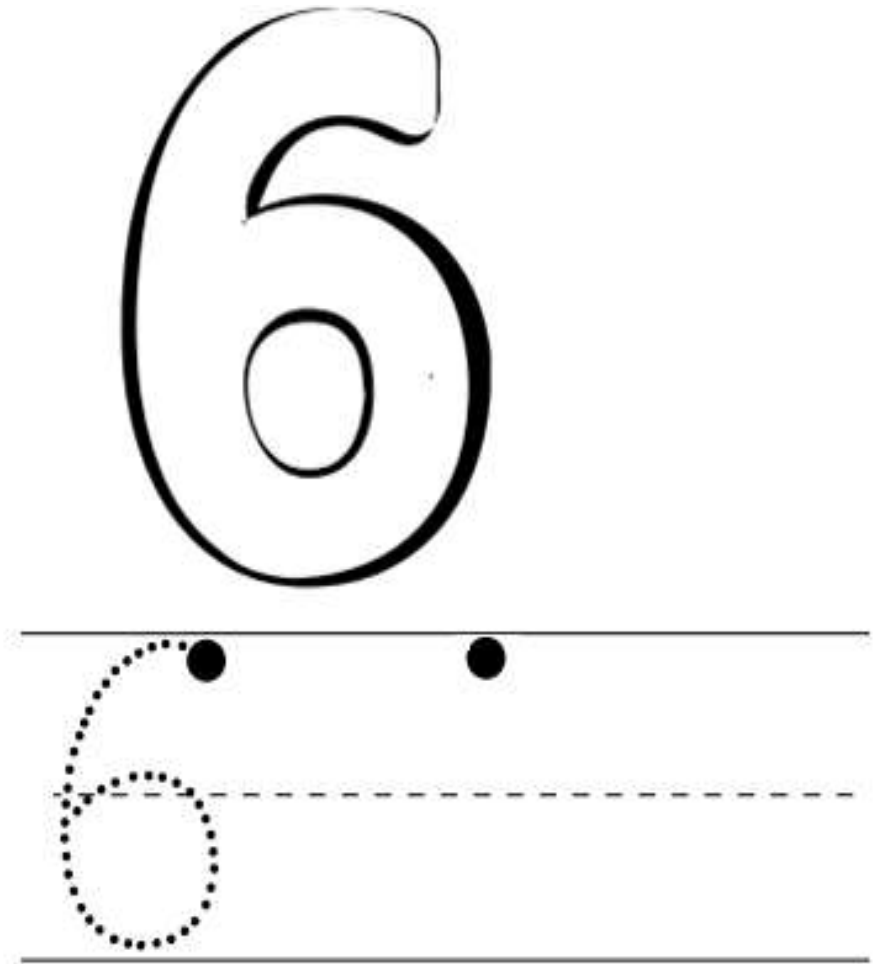
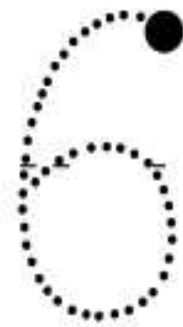
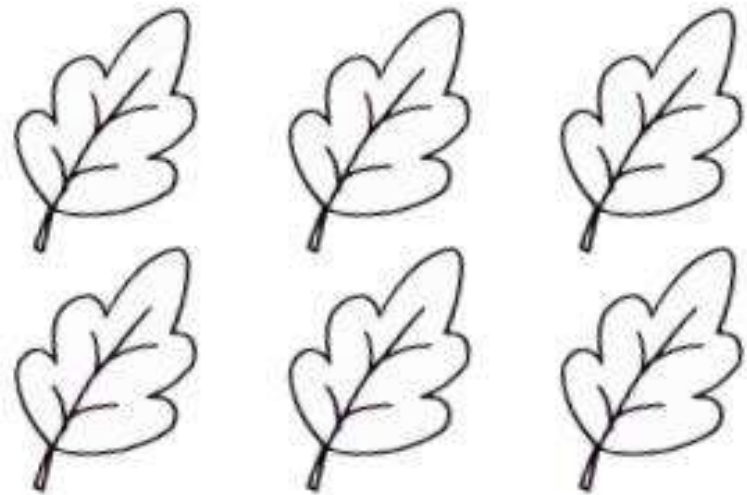



Trace number SEVEN and paint the emojis with color yellow.

seven

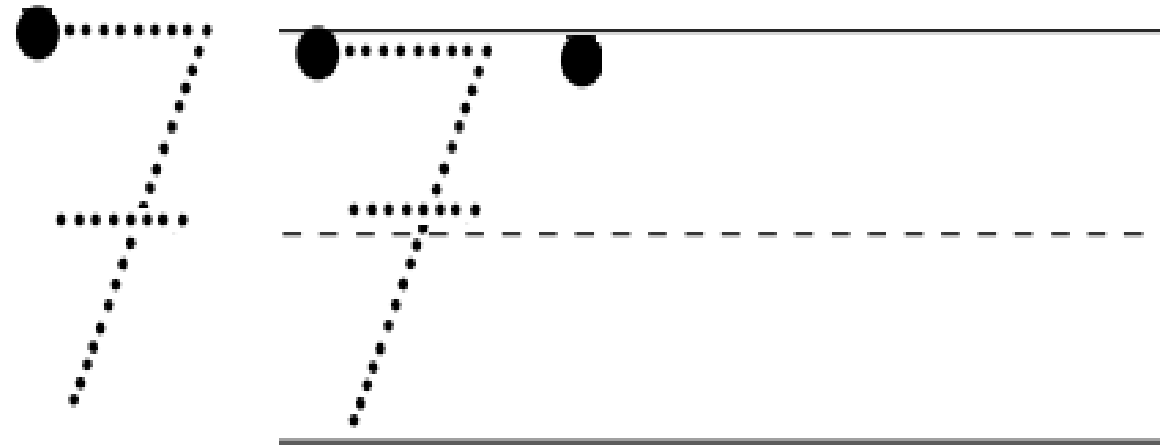
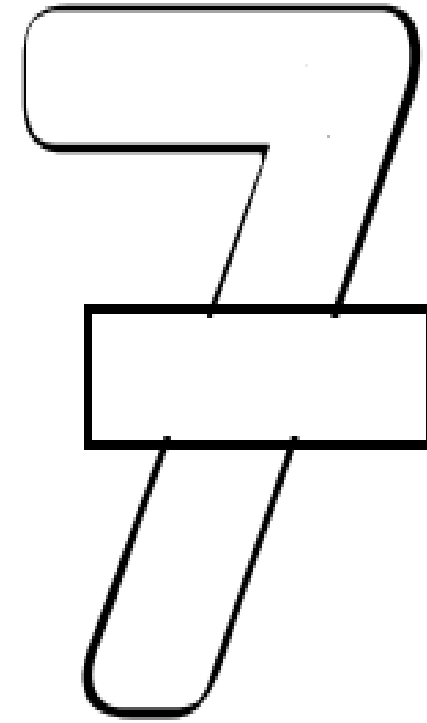
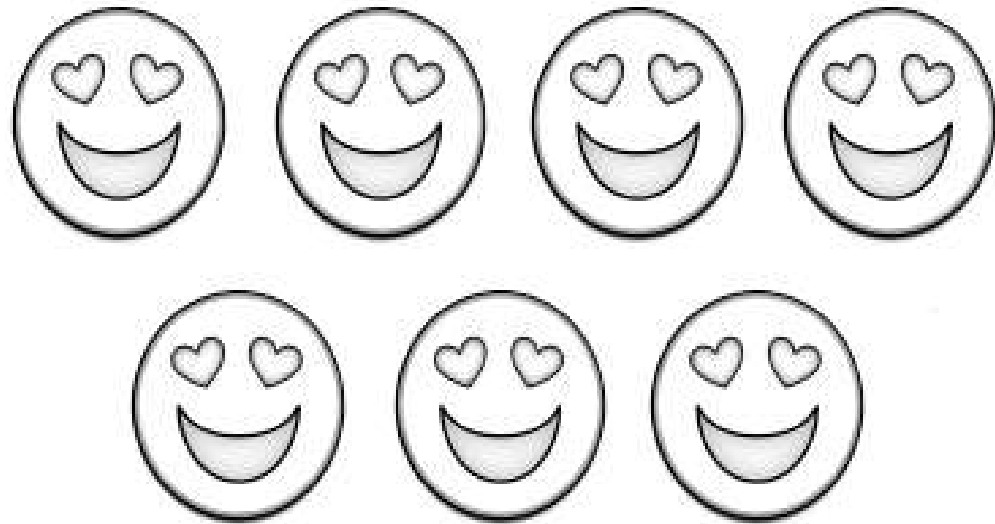

***UNIT 5: Parts of the face:***

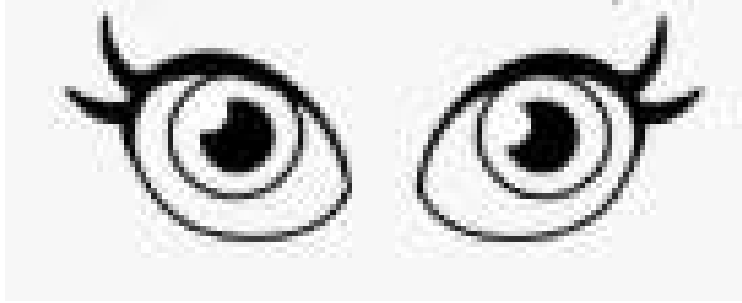

Eyes



Nose

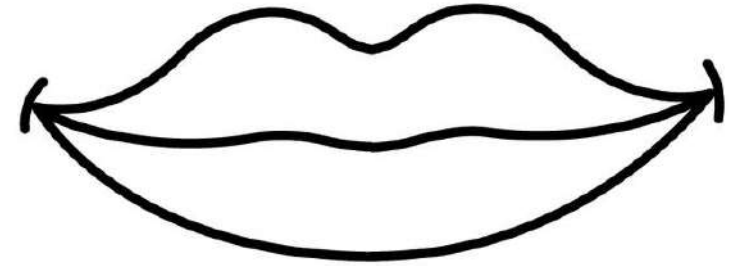

Mouth

***Symmetry activity:***

- Look at the picture, and draw the other part of the boy.

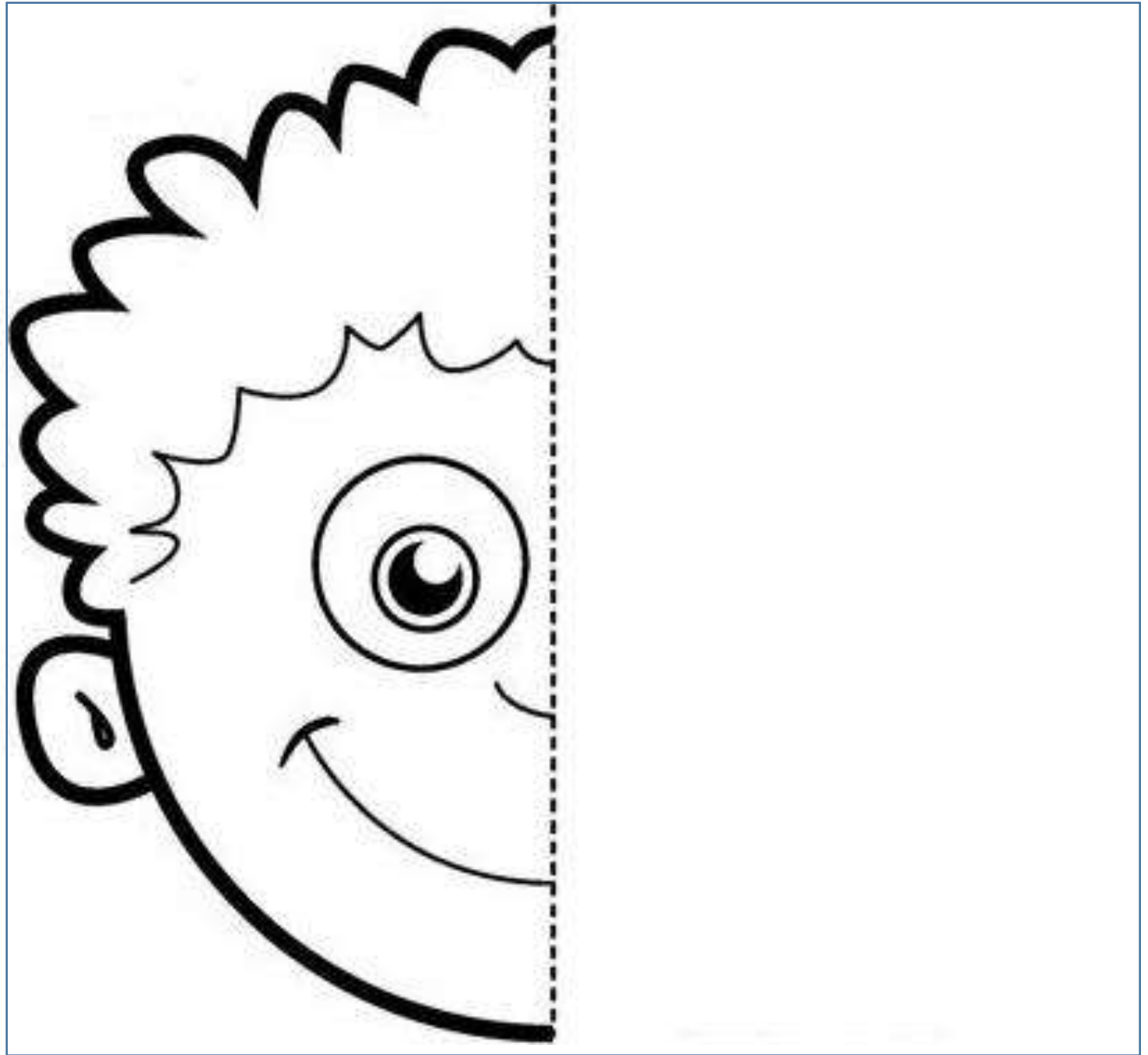

Listen and paint the correct part of the face.

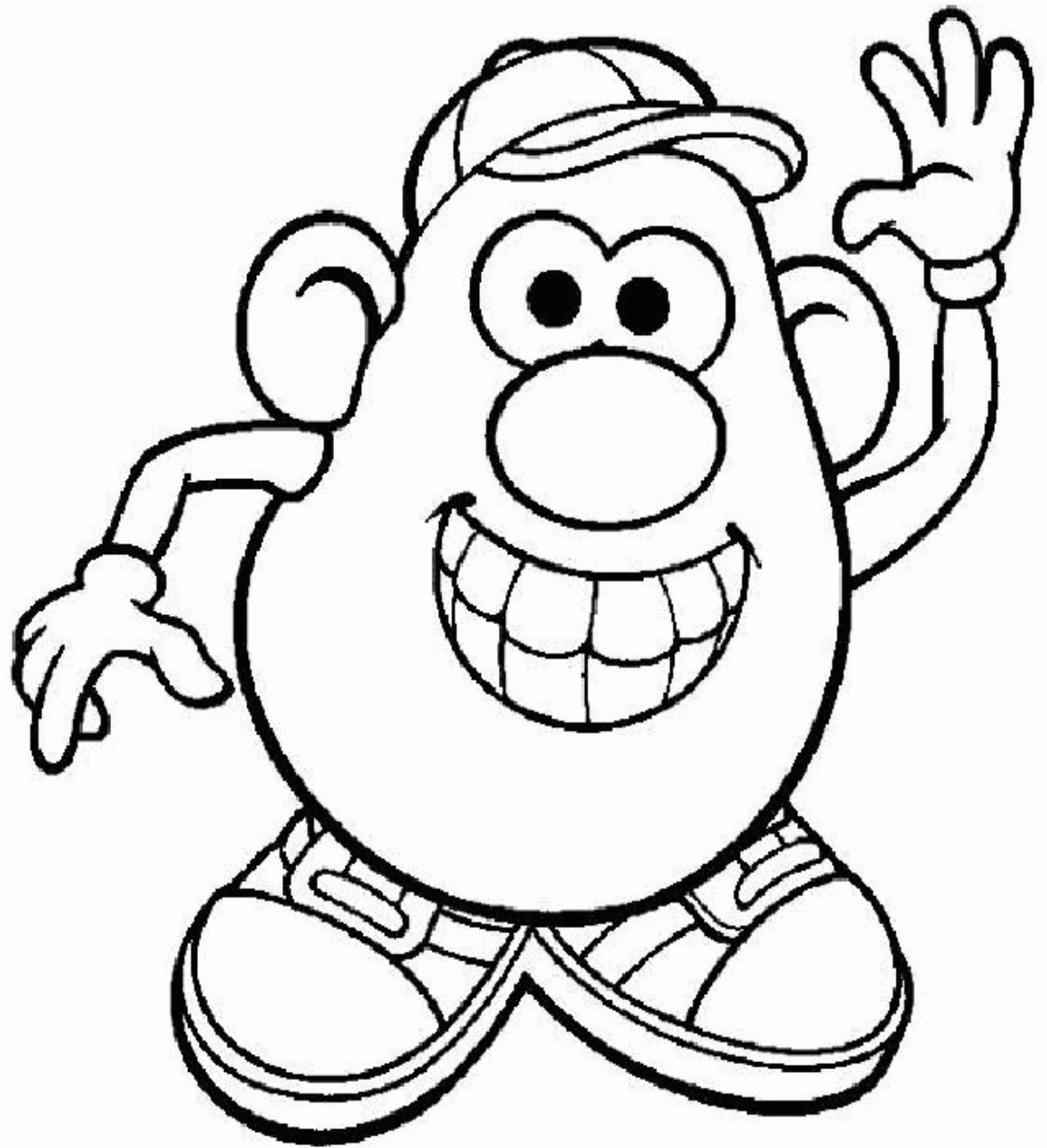

Cut and paste.

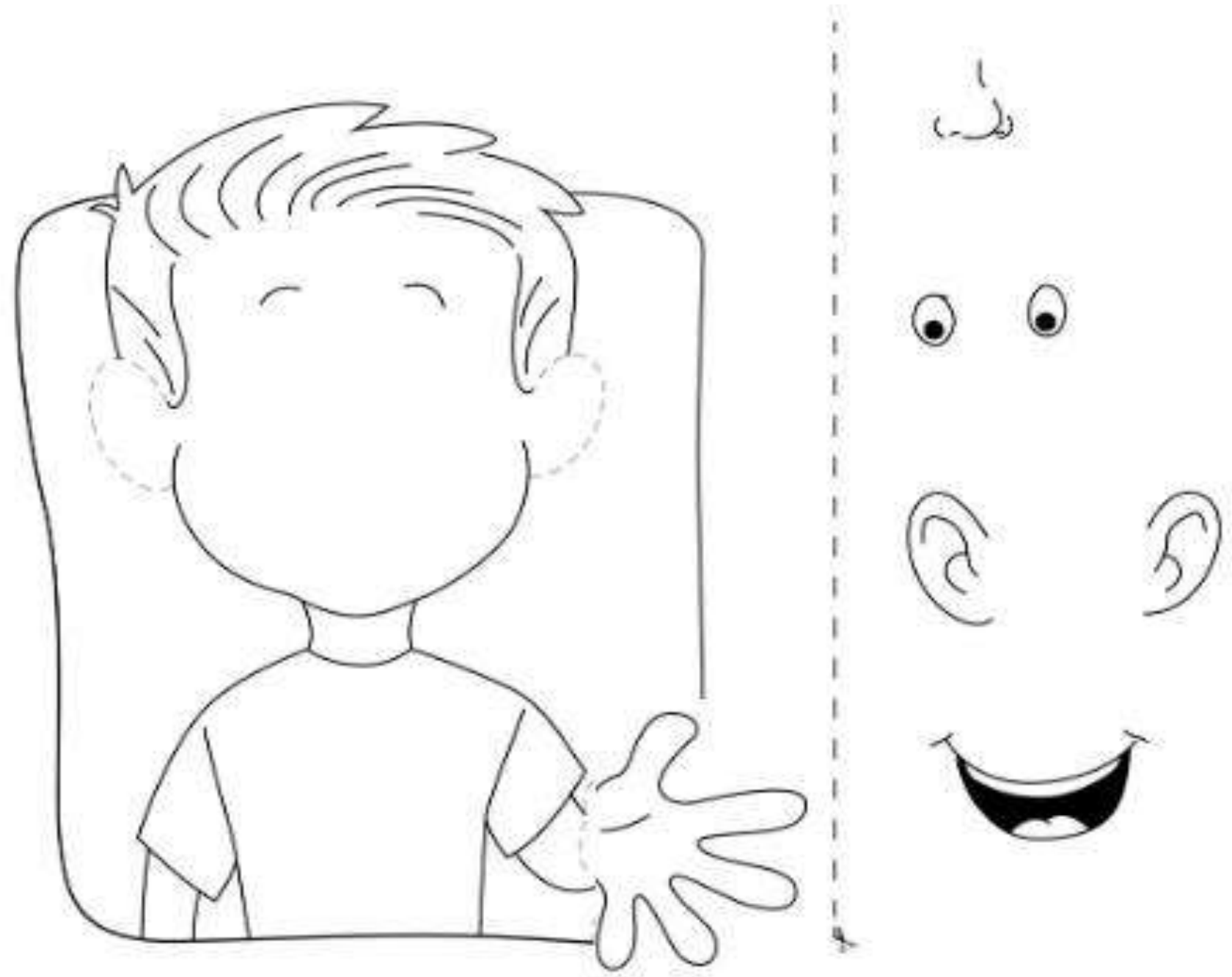

Trace number EIGHT and paint the hearts with color orange.

eight

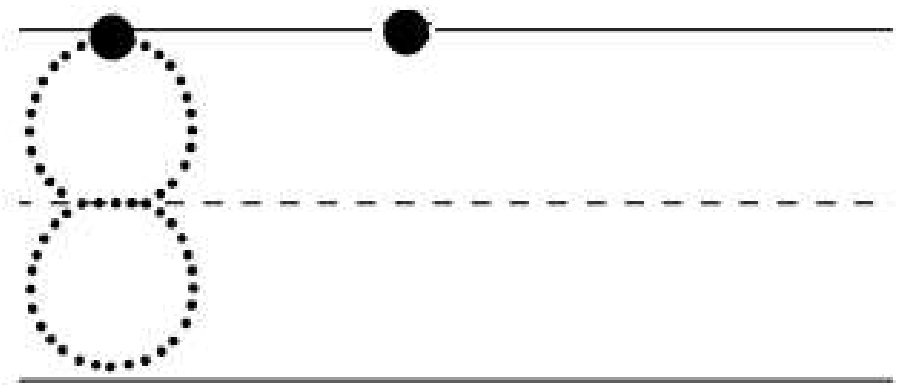
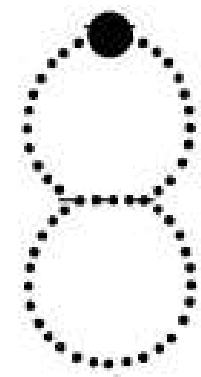
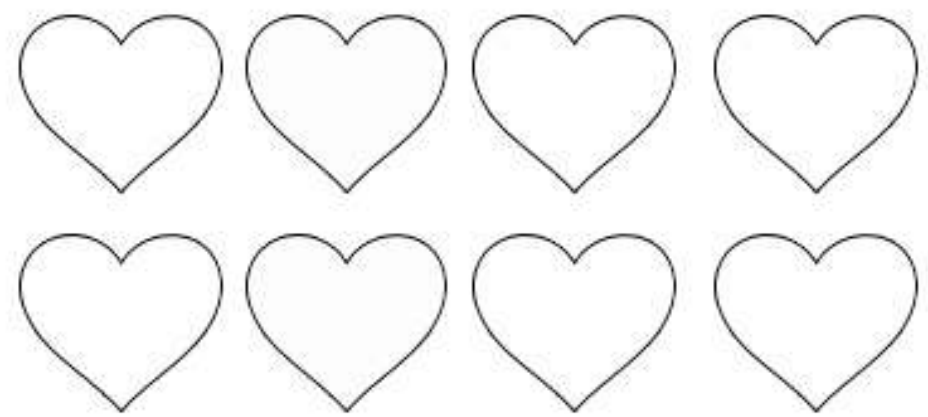
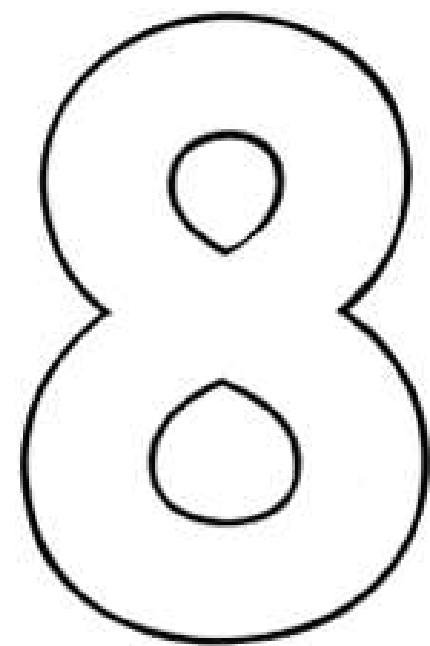

Trace number NINE and paint the ducks with color brown.

nine

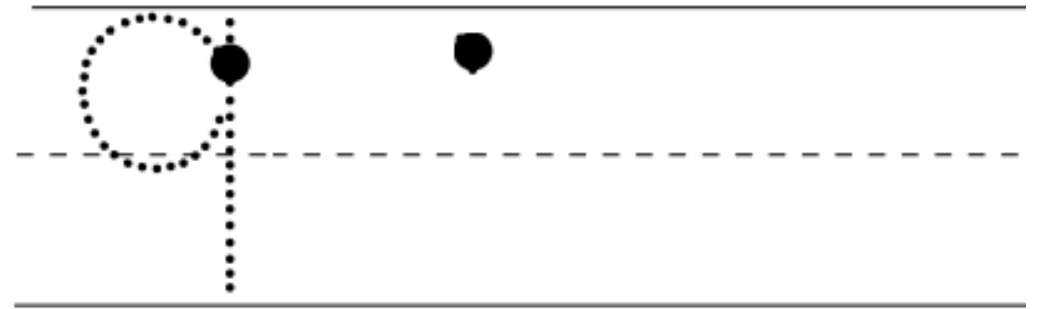
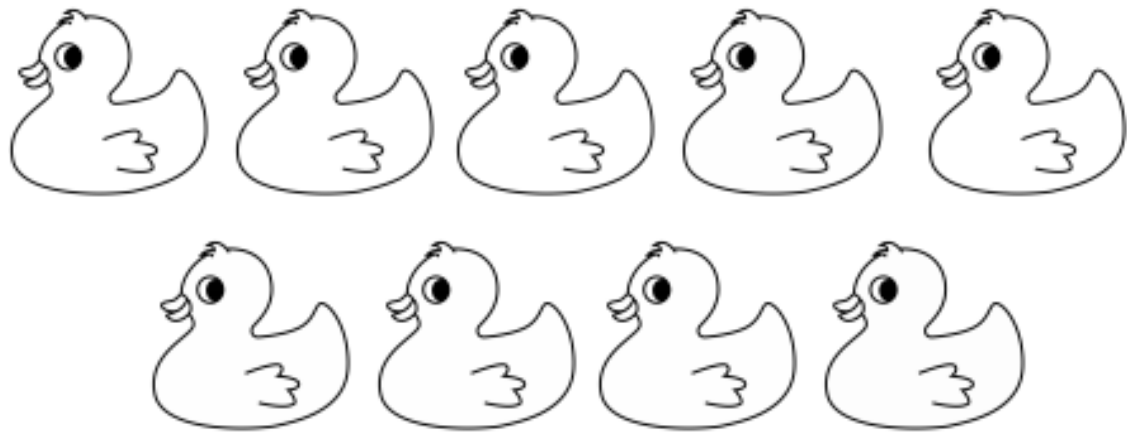

Trace number TEN and paint the ice cream with color purple.

Ten

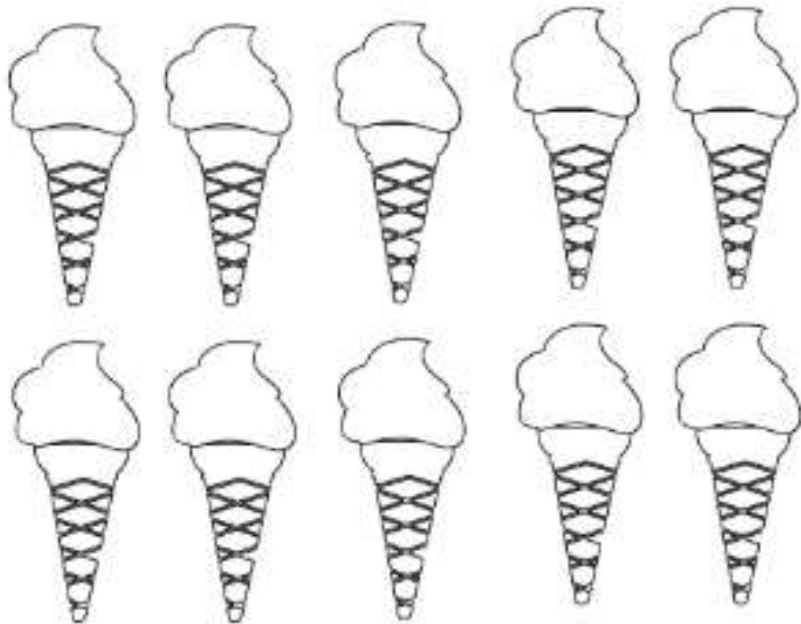

10

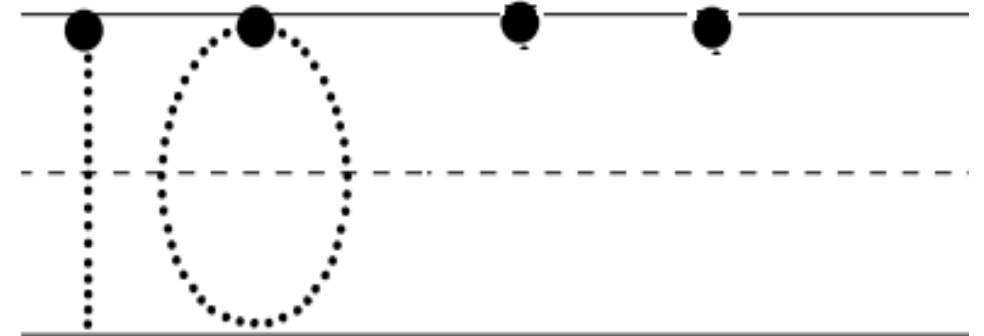
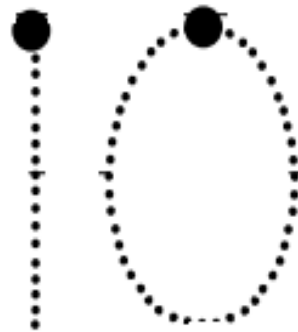



***UNIT 6: Feelings***



Happy



Sad



Angry

Listen and draw the correct feelings.

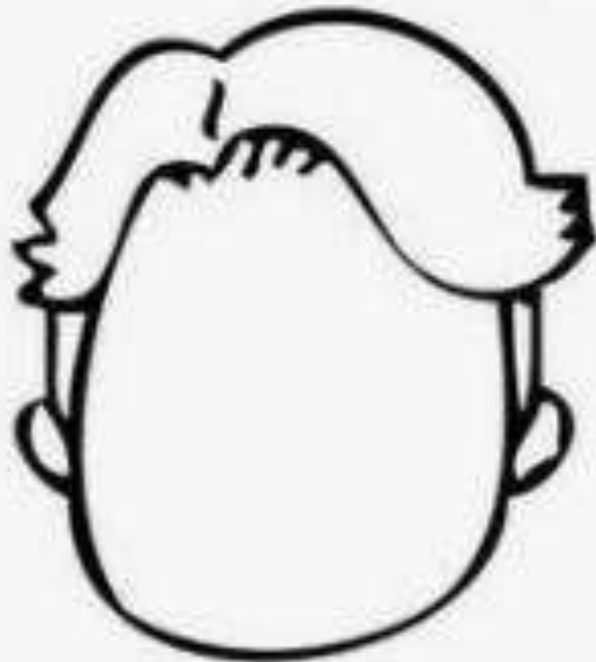

I'm happy



I'm sad

Look at the picture and paint the correct alternative.



Happy

Angry

Sad

Angry



Extra activities: **"SPECIAL DATES"**

Trace and paste little papers color blue, red, yellow or orange.

Happy Easter!

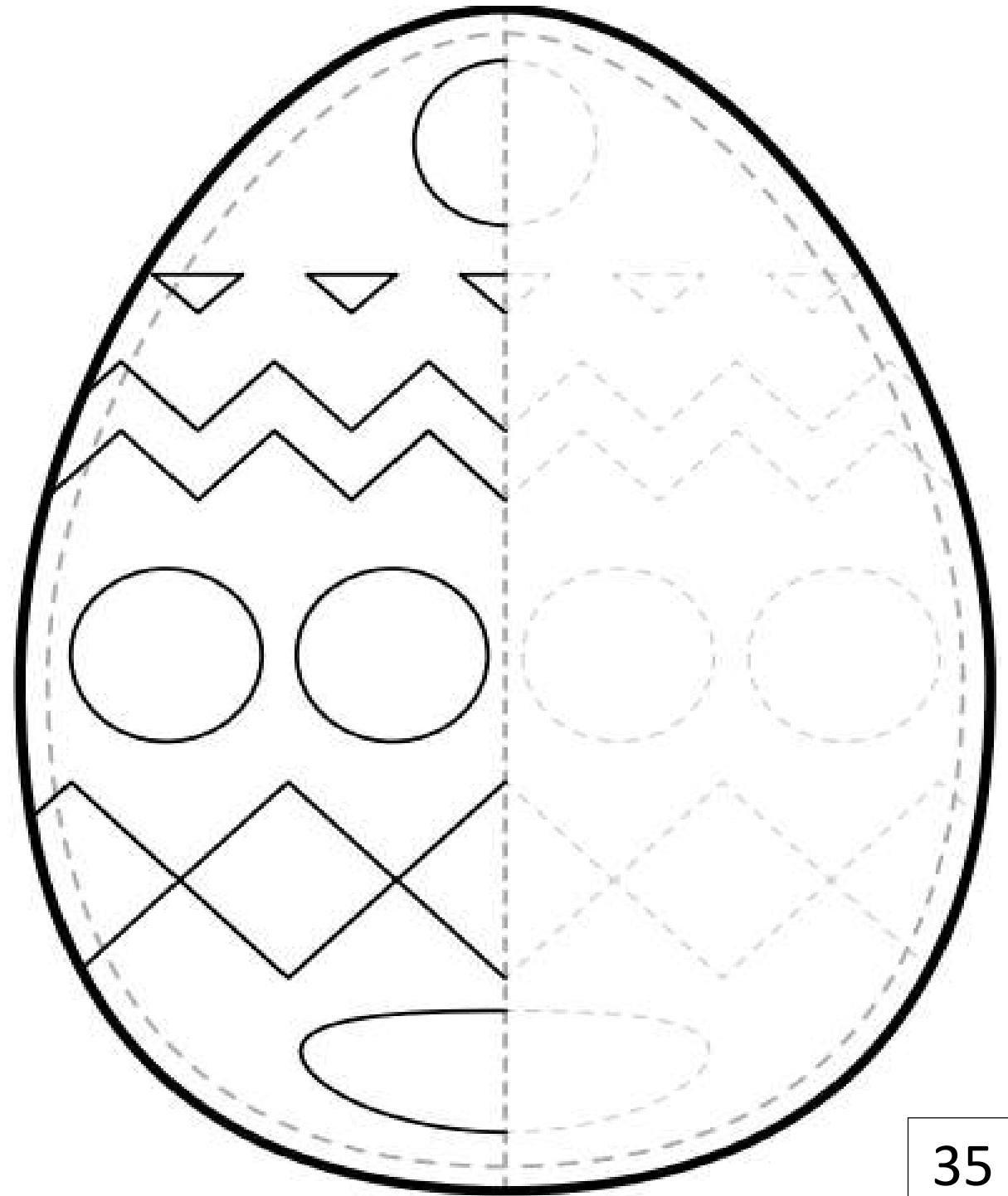
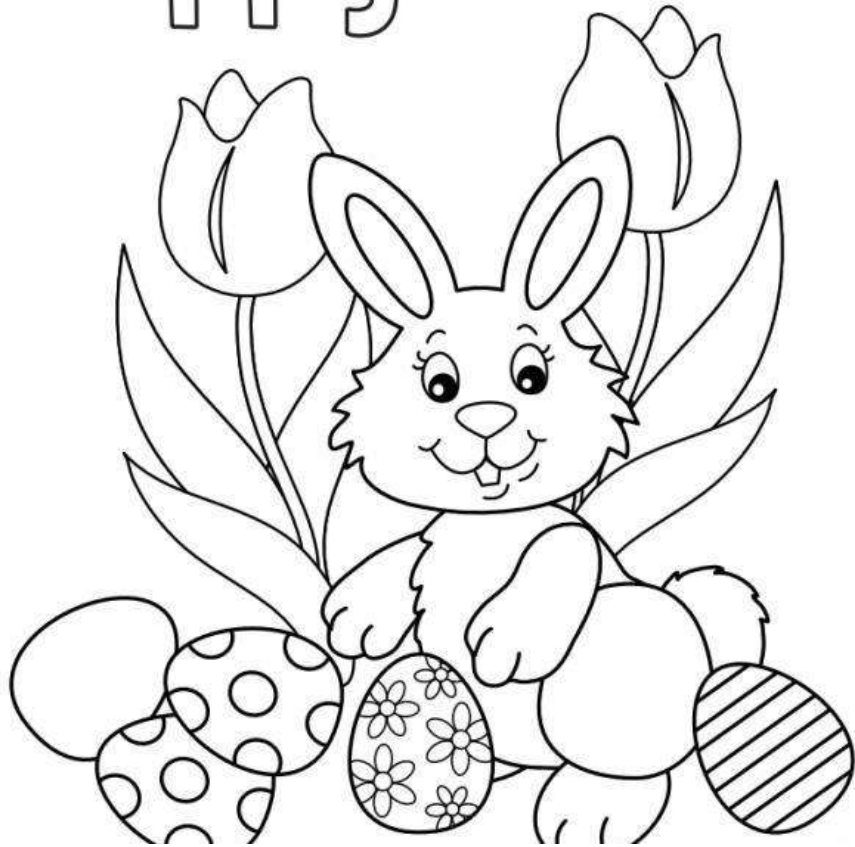

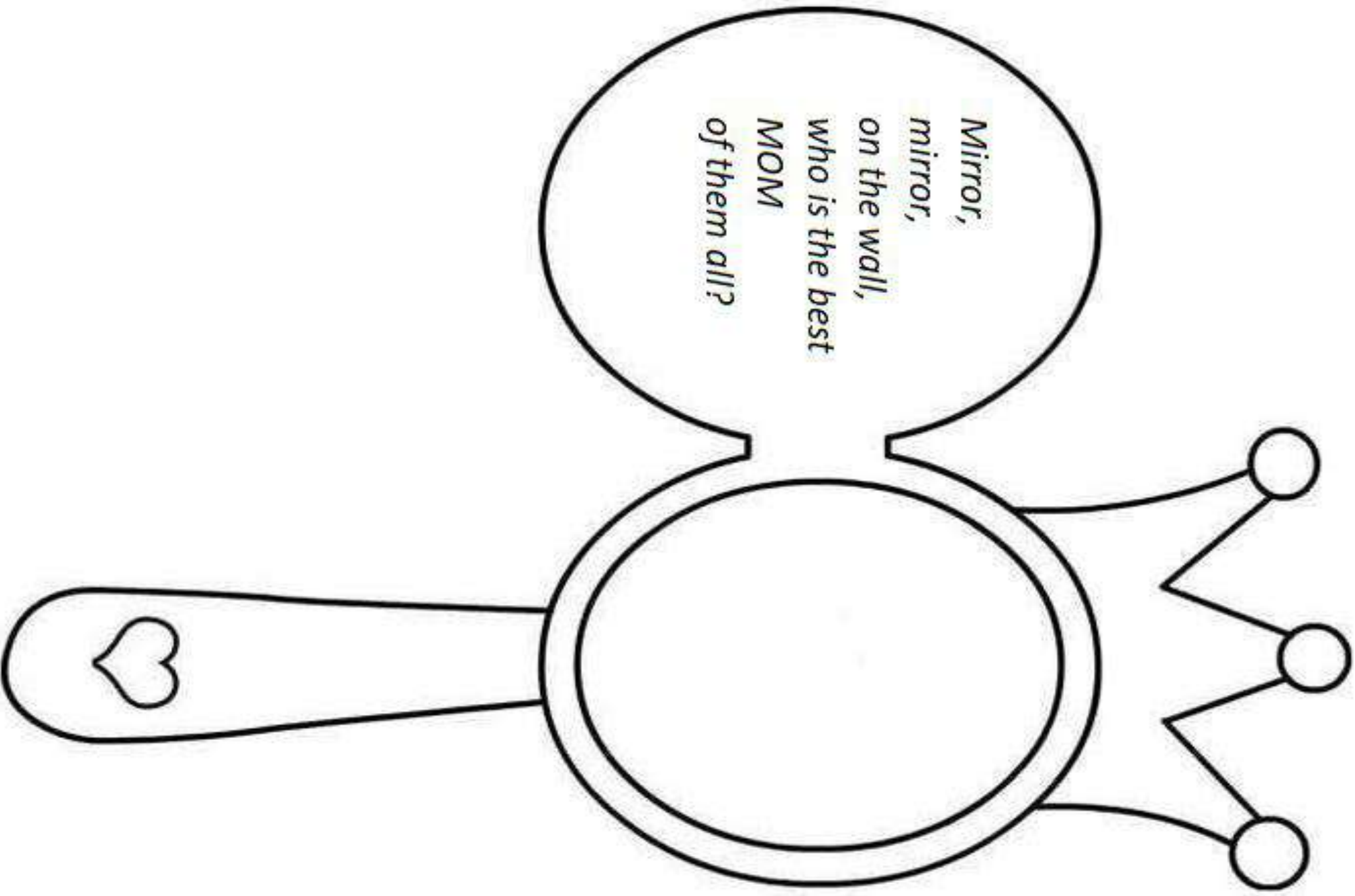

**May 21<sup>st</sup>**

**Recycling activity:**

- Egg cartons (carton de huevos)
- Straws (bombilla)
- Paper (papel- lustre)
- Brush (pincel)
- Paint (pintura - tempera)
- Newspaper (el diario)

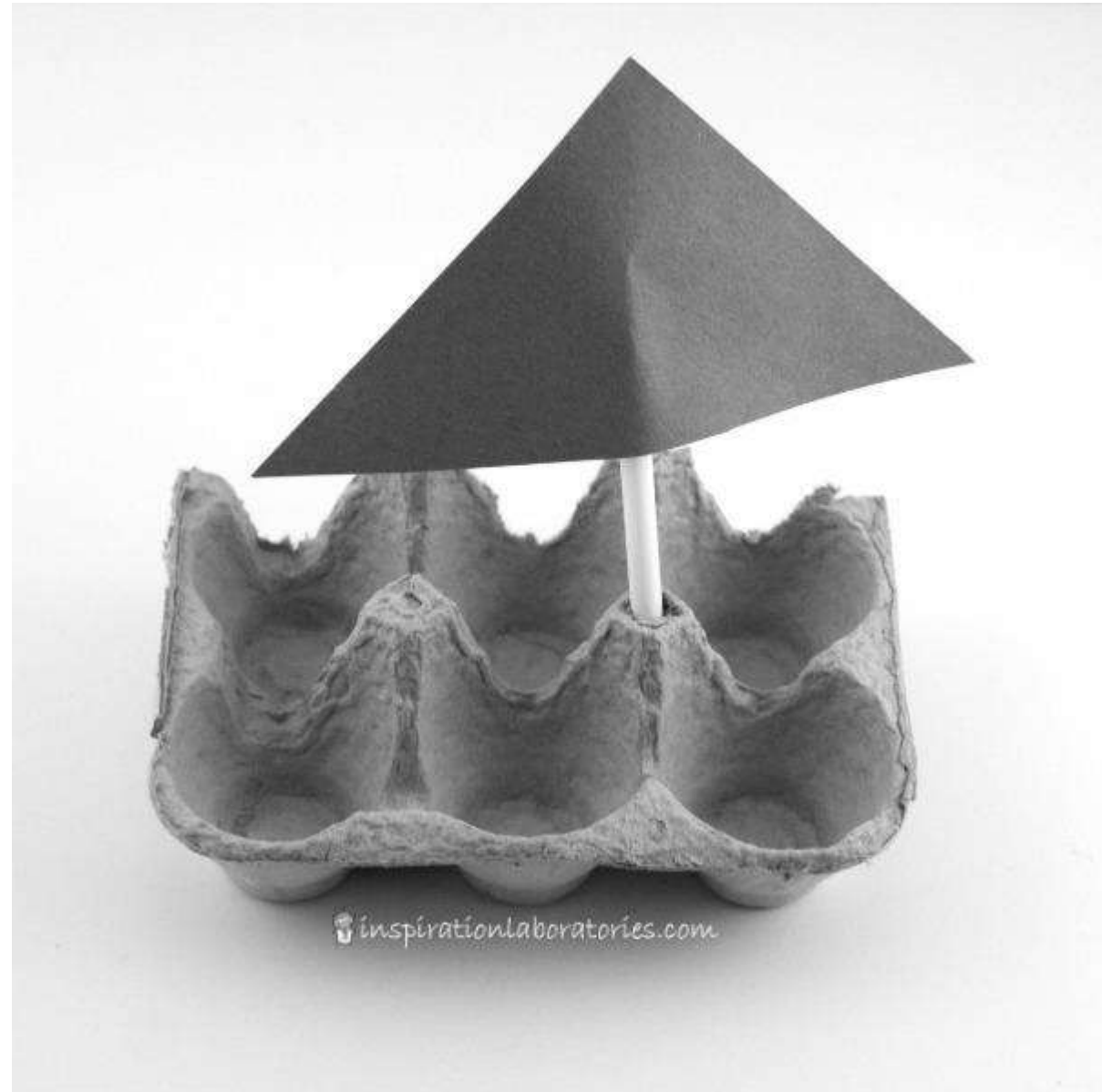

*Father's day*





# September 18<sup>th</sup>

Cut and paste papers with the traditional colors.



Chile



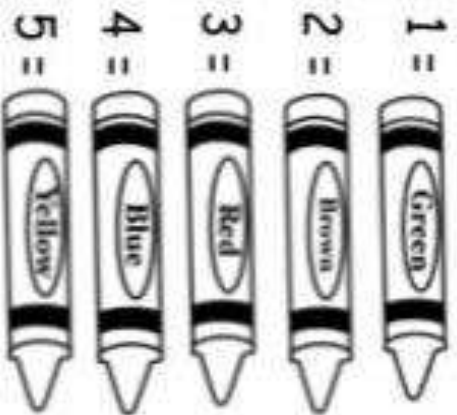

Color By Number

